

SIP/VoIP Call Flow Messages

Version 1.0; October 27, 2006

SIP/VoIP

NOKIA

Copyright © 2006 Nokia Corporation. All rights reserved.

Nokia and Forum Nokia are registered trademarks of Nokia Corporation. Other product and company names mentioned herein may be trademarks or trade names of their respective owners.

Disclaimer

The information in this document is provided “as is,” with no warranties whatsoever, including any warranty of merchantability, fitness for any particular purpose, or any warranty otherwise arising out of any proposal, specification, or sample. Furthermore, information provided in this document is preliminary, and may be changed substantially prior to final release. This document is provided for informational purposes only.

Nokia Corporation disclaims all liability, including liability for infringement of any proprietary rights, relating to implementation of information presented in this document. Nokia Corporation does not warrant or represent that such use will not infringe such rights.

Nokia Corporation retains the right to make changes to this specification at any time, without notice.

License

A license is hereby granted to download and print a copy of this specification for personal use only. No other license to any other intellectual property rights is granted herein.

Contents

1	Introduction	5
2	Basic call handling	6
2.1	Register.....	6
2.2	Callee terminates.....	7
2.3	Caller discards.....	8
2.4	Callee discards.....	9
3	Advanced call handling	11
3.1	Call hold.....	11
3.2	Consultation hold.....	13
3.3	Call swap.....	15
3.4	Unattended transfer.....	19
3.5	Attended transfer.....	22
3.6	Call forwarding – No answer.....	26
3.7	Call forwarding – Busy.....	28
3.8	Call forwarding – Busy (call waiting enabled).....	29
3.9	Register with NAT traversal using STUN.....	31
3.10	Call with NAT traversal using STUN.....	32
4	Failed call situations	34
4.1	Not found.....	34
4.2	Busy here.....	34
4.3	Callee does not answer.....	35
4.4	Anonymous call barring.....	36
4.5	Request timeout.....	37
5	Terms and abbreviations	38
	Evaluate this resource	39

Change history

October 27, 2006	Version 1.0	Initial document release

1 Introduction

The purpose of this document is to present the SIP/VoIP call flow messages in typical situations. This document is aimed at SIP/VoIP developers who are interested in the call flow of messages in various call situations.

The call flow messages shown here are divided into three main chapters, namely basic call handling, advanced call handling, and failed call situations.

2 Basic call handling

2.1 Register

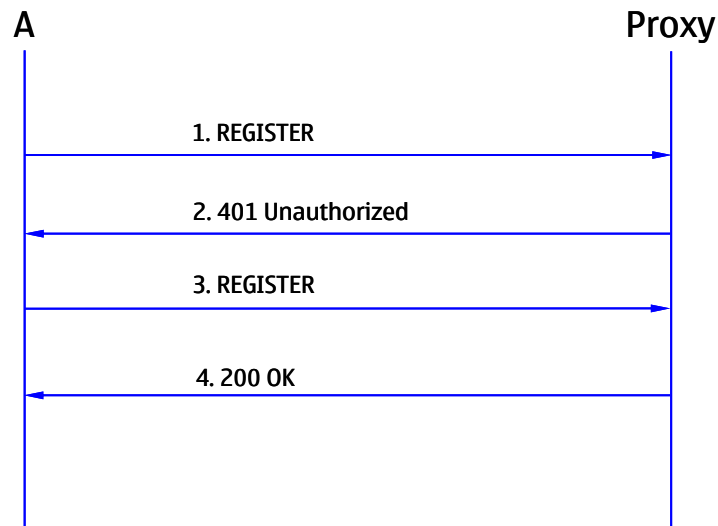

Step	Action	Description
1 - Phone A registers to the proxy	REGISTER	A sends a REGISTER request to the proxy.
2	401 Unauthorized	The proxy challenges A with a 401 response to submit credentials.
3	REGISTER	A resends the REGISTER request with credentials.
4	200 OK	The proxy responds with a 200 response to indicate that A is now registered in the proxy.

Table 1: Caller registers to the proxy

2.2 Callee terminates

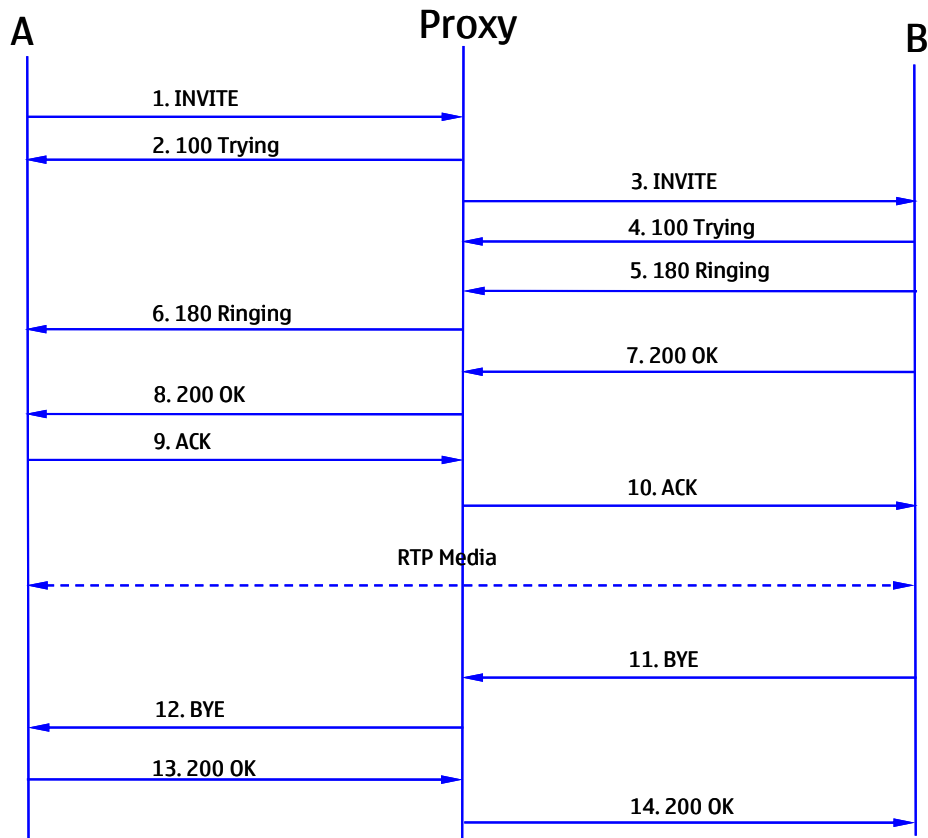

Step	Action	Description
1 - A makes a call to B	INVITE	A sends an INVITE request to the proxy.
2	100 Trying	The proxy sends a 100 response to A to acknowledge that the INVITE request has been received by the proxy.
3	INVITE	An INVITE request is forwarded to B.
4	100 Trying	B sends a 100 response to the proxy to acknowledge that the INVITE request has been received by B.
5	180 Ringing	B sends a 180 response to the proxy to indicate that B is being alerted.
6	180 Ringing	The 180 response is forwarded to A.
7 - B answers the call	200 OK	B sends a 200 response to the proxy. This notifies the proxy that a connection has been established.
8	200 OK	The proxy forwards the 200 response to A.
9	ACK	A acknowledges the 200 response from the proxy.
10	ACK	The proxy forwards the acknowledgement to B.
11 -B terminates the call	BYE	B sends a BYE request to the proxy.
12	BYE	The proxy forwards the BYE request to A.

Step	Action	Description
13	200 OK	A sends a 200 response to the proxy. The 200 response notifies the proxy that A has received the BYE request.
14	200 OK	The proxy forwards the 200 OK response to B.

Table 2: Callee terminates the call

2.3 Caller discards

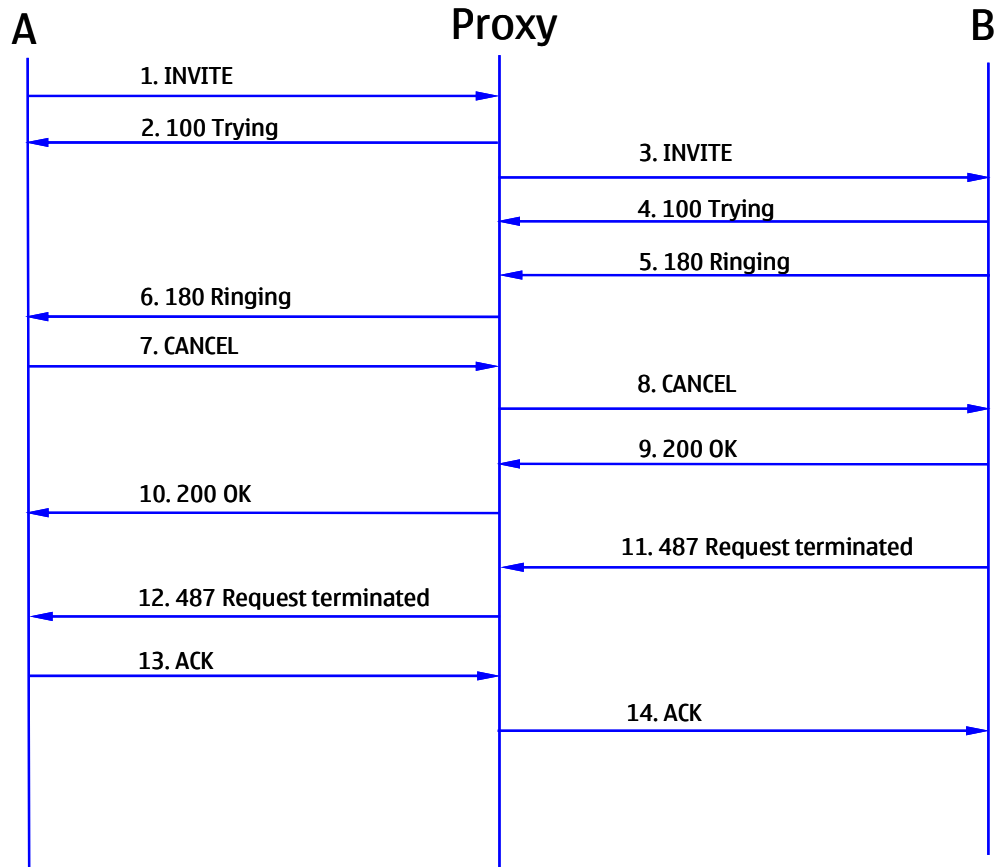

Step	Action	Description
1 - A makes a call to B	INVITE	A sends an INVITE request to the proxy.
2	100 Trying	The proxy sends a 100 response to A to acknowledge that the INVITE request has been received by the proxy.
3	INVITE	The INVITE request is forwarded to B.
4	100 Trying	B sends a 100 response to the proxy to acknowledge that the INVITE request has been received by B.
5	180 Ringing	B sends a 180 response to the proxy to indicate that B is being alerted.
6	180 Ringing	The 180 response is forwarded to A.

Step	Action	Description
7 – A discards the call	CANCEL	A sends a CANCEL request to the proxy to cancel the INVITE.
8	CANCEL	The proxy forwards the CANCEL request to B.
9	200 OK	B sends a 200 response to the proxy. This notifies the proxy that the CANCEL request has been received.
10	200 OK	The proxy forwards the 200 response to A.
11	487 Request terminated	B cancels the INVITE request by sending a 487 response to the proxy.
12	487 Request terminated	The proxy forwards the 487 response to A.
13	ACK	A sends the acknowledgement of the 487 response to the proxy.
14	ACK	The proxy forwards the acknowledgement to B.

Table 3: Caller discards the call

2.4 Callee discards

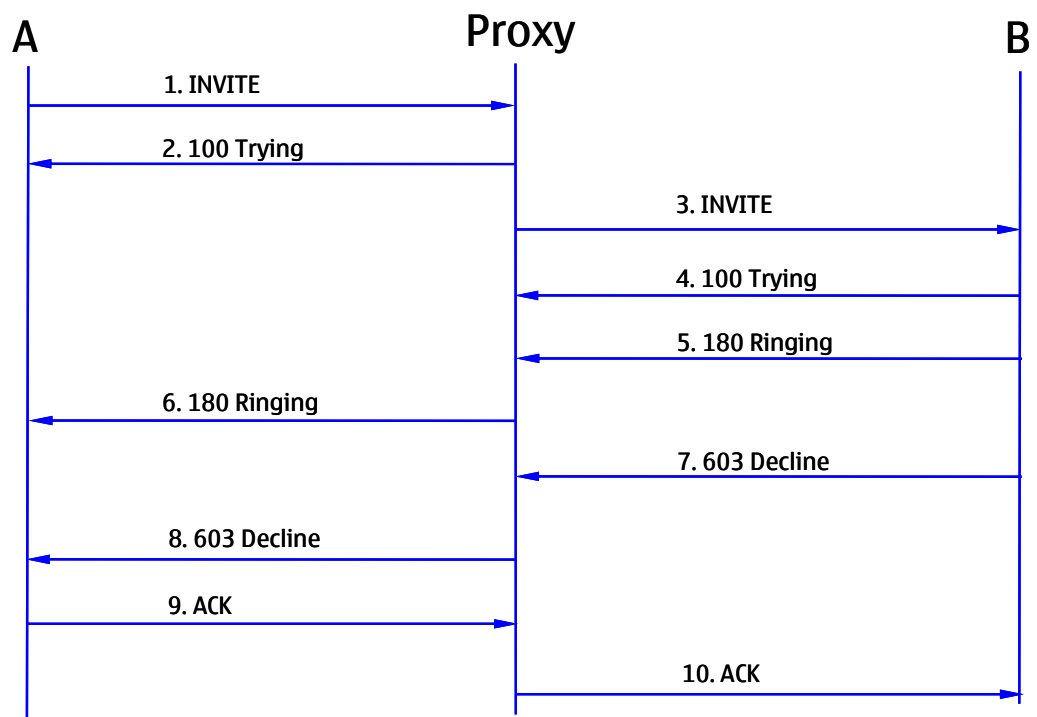

Step	Action	Description
1 - A makes a call to B	INVITE	A sends an INVITE request to the proxy.
2	100 Trying	The proxy sends a 100 response to A to acknowledge that the INVITE request has been received by the proxy.

Step	Action	Description
3	INVITE	The INVITE request is forwarded to B.
4	100 Trying	B sends a 100 response to the proxy to acknowledge that the INVITE request has been received by B.
5	180 Ringing	B sends a 180 response to the proxy to indicate that B is being alerted.
6	180 Ringing	The 180 response is forwarded to A.
7 – B discards the call	603 Decline	B sends a 603 response to A.
8	603 Decline	The proxy forwards the 603 response to A.
9	ACK	A sends an acknowledgement of the call decline to the proxy.
10	ACK	The proxy forwards the acknowledgement to B.

Table 4: Callee discards the call

3 Advanced call handling

3.1 Call hold

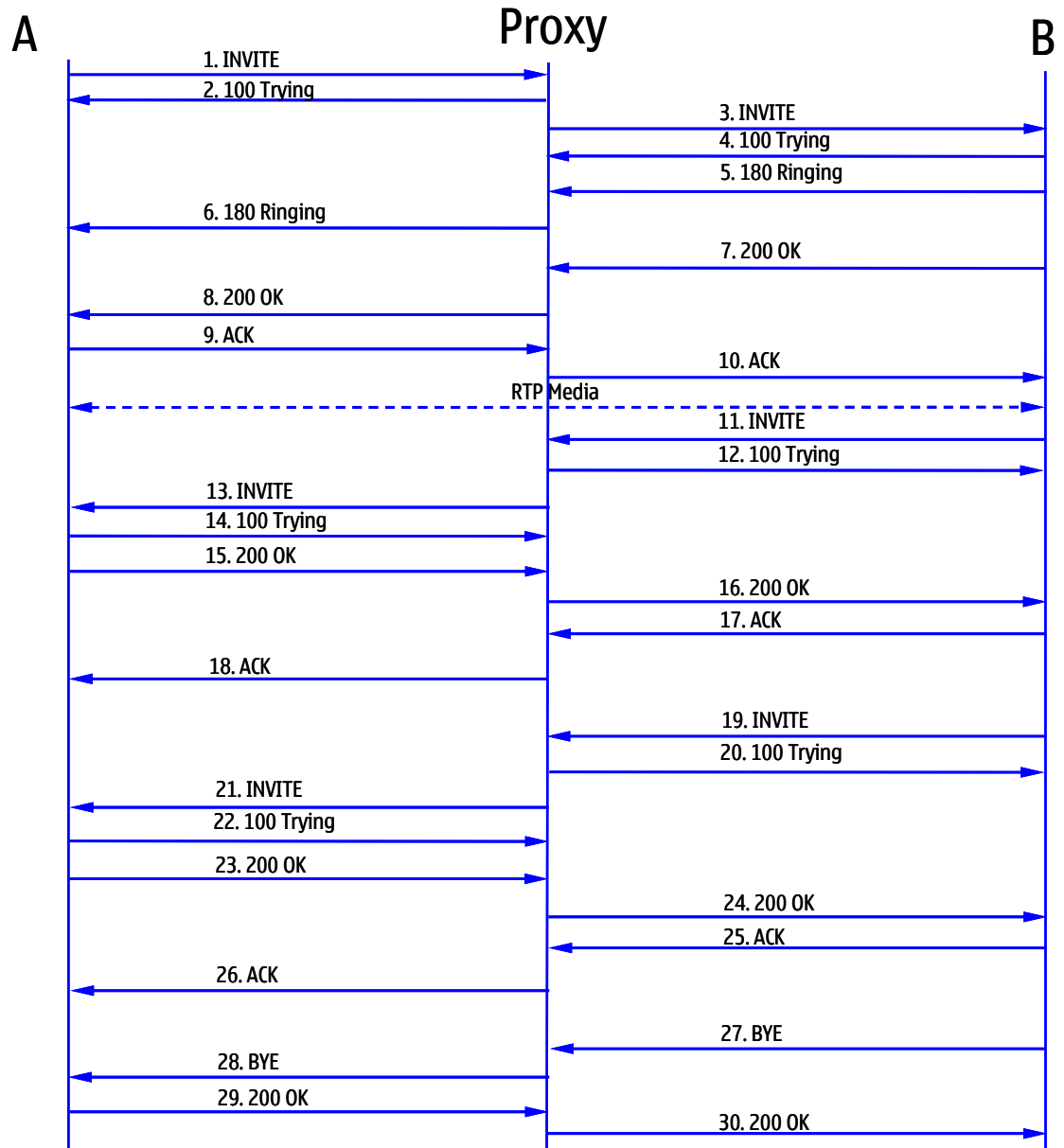

Step	Action	Description
1	INVITE	A sends an INVITE request to the proxy.
2	100 Trying	The proxy sends a 100 response to A to acknowledge that the INVITE request has been received by the proxy.
3	INVITE	The INVITE request is forwarded to B.
4	100 Trying	B sends a 100 response to the proxy to acknowledge that the INVITE request has been received by B.

Step	Action	Description
5	180 Ringing	B sends a 180 response to the proxy to indicate that B is being alerted.
6	180 Ringing	The 180 response is forwarded to A.
7 – B answers the call	200 OK	B sends a 200 response to the proxy. This notifies the proxy that a connection has been established.
8	200 OK	The proxy forwards the 200 response to A.
9	ACK	A acknowledges the 200 response from the proxy.
10	ACK	The proxy forwards the acknowledgement to B.
11 – B puts the call on hold	INVITE	B sends a new INVITE request to the proxy with the order to put the call on hold.
12	100 Trying	The proxy sends a 100 response to B to acknowledge that the INVITE request has been received by the proxy.
13	INVITE	The proxy forwards an INVITE request to A.
14	100 Trying	A sends a 100 response to the proxy to acknowledge that the INVITE request has been received by A.
15	200 OK	A sends a 200 response to the proxy.
16	200 OK	Proxy forwards 200 response to B.
17	ACK	B acknowledges the 200 response from the proxy.
18	ACK	The proxy forwards the acknowledgement to A.
19 – B takes the call from hold	INVITE	B sends a new INVITE request to the proxy with the order to take the call from hold.
20	100 Trying	The proxy sends a 100 response to B to acknowledge that the INVITE request has been received by the proxy.
21	INVITE	The proxy forwards the INVITE request to A.
22	100 Trying	A sends a 100 response to the proxy to acknowledge that the INVITE request has been received by A.
23	200 OK	A sends a 200 response to the proxy.
24	200 OK	The proxy forwards a 200 response to B.
25	ACK	B acknowledges the 200 response from the proxy.
26	ACK	The proxy forwards the acknowledgement to A.
27 –B terminates the call	BYE	B sends a BYE request to the proxy.
28	BYE	The proxy forwards the BYE request to A.
29	200 OK	A sends a 200 response to the proxy. The 200 response notifies the proxy that A has received the BYE request.
30	200 OK	The proxy forwards the 200 OK response to B.

Table 5: Call hold

3.2 Consultation hold

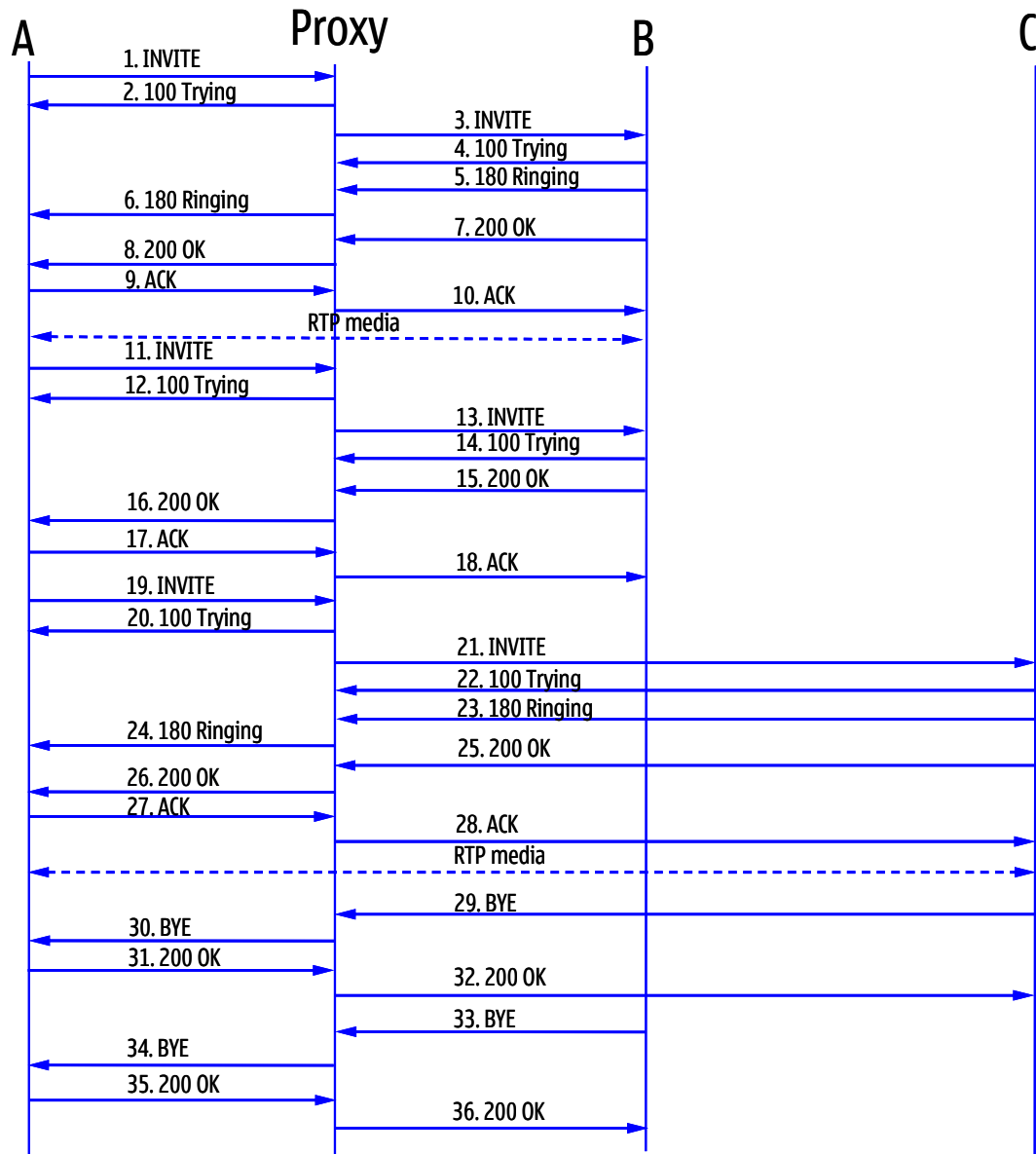

Step	Action	Description
1 - A makes a call to B	INVITE	A sends an INVITE request to the proxy.
2	100 Trying	The proxy sends a 100 response to A to acknowledge that the INVITE request has been received by the proxy.
3	INVITE	The INVITE request is forwarded to B.
4	100 Trying	B sends a 100 response to the proxy to acknowledge that the INVITE request has been received by B.
5	180 Ringing	B sends a 180 response to the proxy to indicate that B is being alerted.
6	180 Ringing	The 180 response is forwarded to A.

Step	Action	Description
7 – B answers the call	200 OK	B sends a 200 response to the proxy. This notifies the proxy that a connection has been established.
8	200 OK	The proxy forwards the 200 response to A.
9	ACK	A acknowledges the 200 response from the proxy.
10	ACK	The proxy forwards the acknowledgement to B.
11 – A puts B on hold	INVITE	A sends a new INVITE request to the proxy with the order to put the call on hold.
12	100 Trying	The proxy sends a 100 response to A to acknowledge that the INVITE request has been received by the proxy.
13	INVITE	The proxy forwards the INVITE request to B.
14	100 Trying	B sends a 100 response to the proxy to acknowledge that the INVITE request has been received by B.
15	200 OK	B sends a 200 response to the proxy.
16	200 OK	The proxy forwards the 200 response to A.
17	ACK	A acknowledges the 200 response from the proxy.
18	ACK	The proxy forwards the acknowledgement to B.
19 – A makes a consultation call to C	INVITE	A sends an INVITE request to the proxy.
20	100 Trying	The proxy sends a 100 response to A to acknowledge that the INVITE request is proceeding.
21	INVITE	The INVITE request is forwarded to C.
22	100 Trying	C sends a 100 response to the proxy to acknowledge that the INVITE request has been received by C.
23	180 Ringing	C sends a 180 response to the proxy to indicate that C is being alerted.
24	180 Ringing	The 180 response is forwarded to A.
25 – C answers the call	200 OK	C sends a 200 response to the proxy. This notifies the proxy that a connection has been established.
26	200 OK	The proxy forwards the 200 response to A.
27	ACK	A acknowledges the 200 response from the proxy.
28	ACK	The proxy forwards the acknowledgement to C.
29 –C terminates the call	BYE	C sends a BYE request to the proxy.
30	BYE	The proxy forwards the BYE request to A.
31	200 OK	A sends a 200 response to the proxy. The 200 response notifies the proxy that A has received the BYE request.
32	200 OK	The proxy forwards the 200 OK response to C.
33 –B terminates the call	BYE	B sends a BYE request to the proxy.

Step	Action	Description
34	BYE	The proxy forwards the BYE request to A.
35	200 OK	A sends a 200 response to the proxy. The 200 response notifies the proxy that A has received the BYE request.
36	200 OK	The proxy forwards the 200 OK response to B.

Table 6: Consultation hold

3.3 Call swap

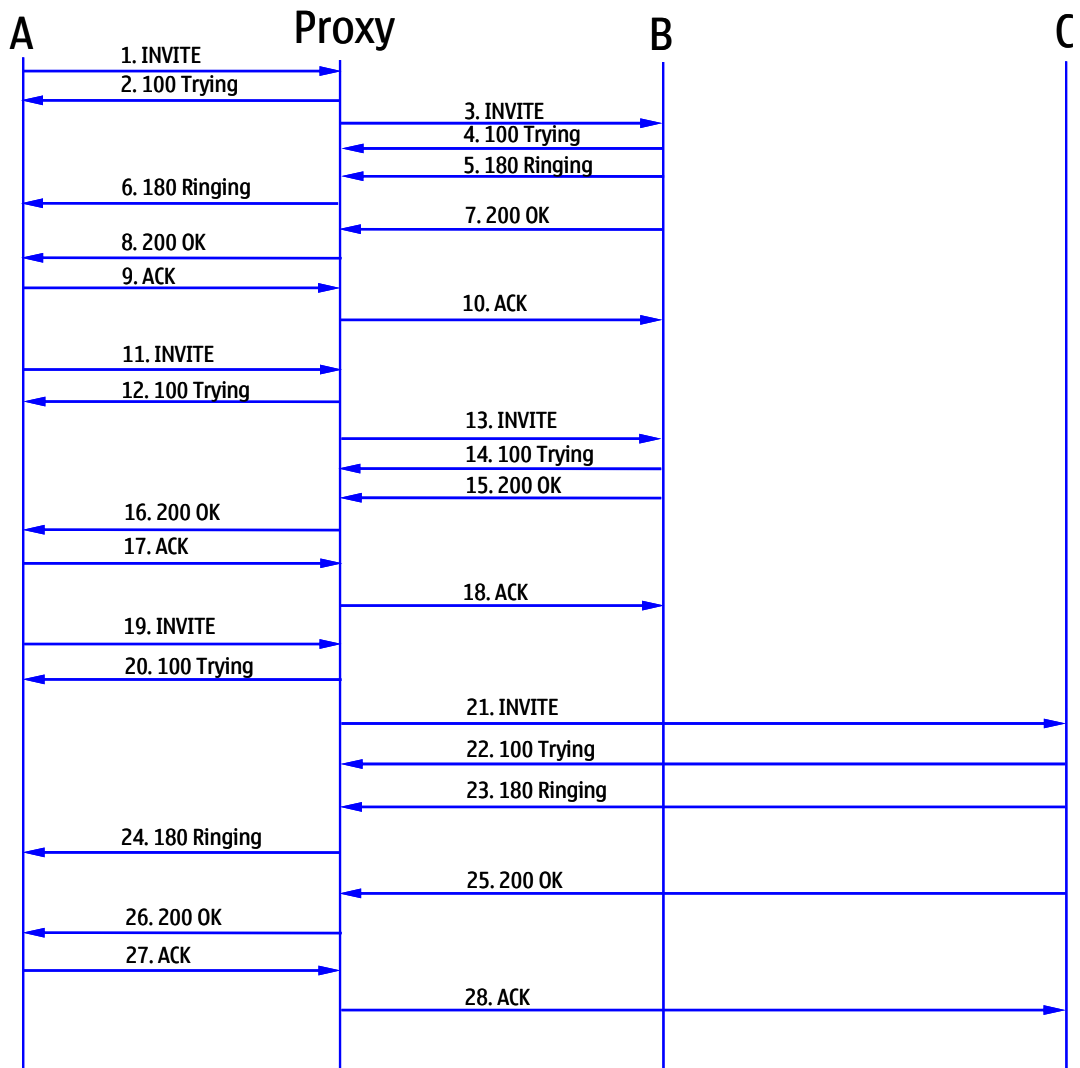

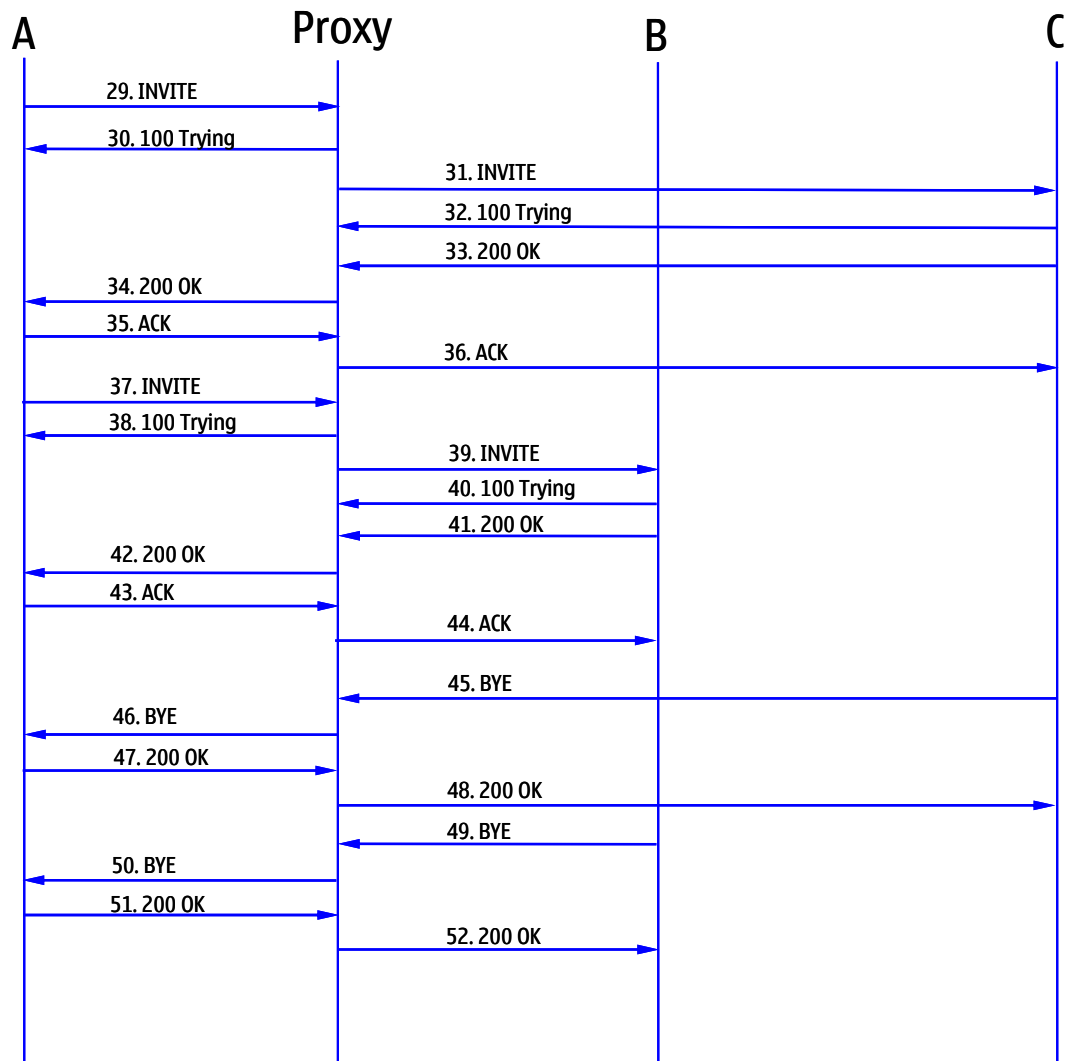

Step	Action	Description
1 - A makes a call to B	INVITE	A sends an INVITE request to the proxy.
2	100 Trying	The proxy sends a 100 response to A to acknowledge that the INVITE request has been received by the proxy.
3	INVITE	The INVITE request is forwarded to B.
4	100 Trying	B sends a 100 response to the proxy to acknowledge that the INVITE request has been received by B.
5	180 Ringing	B sends a 180 response to the proxy to indicate that B is being alerted.
6	180 Ringing	The 180 response is forwarded to A.
7 - B answers the call	200 OK	B sends a 200 response to the proxy. This notifies the proxy that a connection has been established.
8	200 OK	The proxy forwards the 200 response to A.
9	ACK	A acknowledges the 200 response from the proxy.

Step	Action	Description
10	ACK	The proxy forwards the acknowledgement to B.
11 – A puts B on hold	INVITE	A sends a new INVITE request to the proxy with the order to put the call on hold.
12	100 Trying	The proxy sends a 100 response to A to acknowledge that the INVITE request has been received by the proxy.
13	INVITE	The proxy forwards the INVITE request to B.
14	100 Trying	B sends a 100 response to the proxy to acknowledge that the INVITE request has been received by B.
15	200 OK	B sends a 200 response to the proxy.
16	200 OK	The proxy forwards the 200 response to A.
17	ACK	A acknowledges the 200 response from the proxy.
18	ACK	The proxy forwards the acknowledgement to B.
19 – A makes call to C	INVITE	A sends an INVITE request to the proxy.
20	100 Trying	The proxy sends a 100 response to A to acknowledge that the INVITE request has been received by the proxy.
21	INVITE	The INVITE request is forwarded to C.
22	100 Trying	C sends a 100 response to the proxy to acknowledge that the INVITE request has been received by C.
23	180 Ringing	C sends a 180 response to the proxy to indicate that C is being alerted.
24	180 Ringing	The 180 response is forwarded to A.
25 – C answers the call	200 OK	C sends a 200 response to the proxy. This notifies the proxy that a connection has been established.
26	200 OK	The proxy forwards the 200 response to A.
27	ACK	A acknowledges the 200 response from the proxy.
28	ACK	The proxy forwards the acknowledgement to C.
29 – A swaps holds between B and C	INVITE	A sends a new INVITE request to the proxy with the order to put the call on hold.
30	100 Trying	The proxy sends a 100 response to A to acknowledge that the INVITE request has been received by the proxy.
31	INVITE	The proxy forwards an INVITE request to C.
32	100 Trying	C sends a 100 response to the proxy to acknowledge that the INVITE request has been received by C.
33	200 OK	C sends a 200 response to the proxy.
34	200 OK	The proxy forwards the 200 response to A.
35	ACK	A acknowledges the 200 response from the proxy.
36	ACK	The proxy forwards the acknowledgement to C.

Step	Action	Description
37	INVITE	A sends a new INVITE request to the proxy with the order to take the call from hold.
38	100 Trying	The proxy sends a 100 response to A to acknowledge that the INVITE request has been received by the proxy.
39	INVITE	The proxy forwards the INVITE request to C.
40	100 Trying	C sends a 100 response to the proxy to acknowledge that the INVITE request has been received by C.
41	200 OK	C sends a 200 response to the proxy.
42	200 OK	The proxy forwards the 200 response to A.
43	ACK	A acknowledges the 200 response from the proxy.
44	ACK	The proxy forwards the acknowledgement to C.
45 –C terminates the call	BYE	C sends a BYE request to the proxy.
46	BYE	The proxy forwards the BYE request to B.
47	200 OK	A sends a 200 response to the proxy. The 200 response notifies the proxy that A has received the BYE request.
48	200 OK	The proxy forwards the 200 response to C.
49 –B terminates the call	BYE	B sends a BYE request to the proxy.
50	BYE	The proxy forwards the BYE request to A.
51	200 OK	A sends a 200 response to the proxy. The 200 response notifies the proxy that A has received the BYE request.
52	200 OK	The proxy forwards the 200 response to B.

Table 7: Call swap

3.4 Unattended transfer

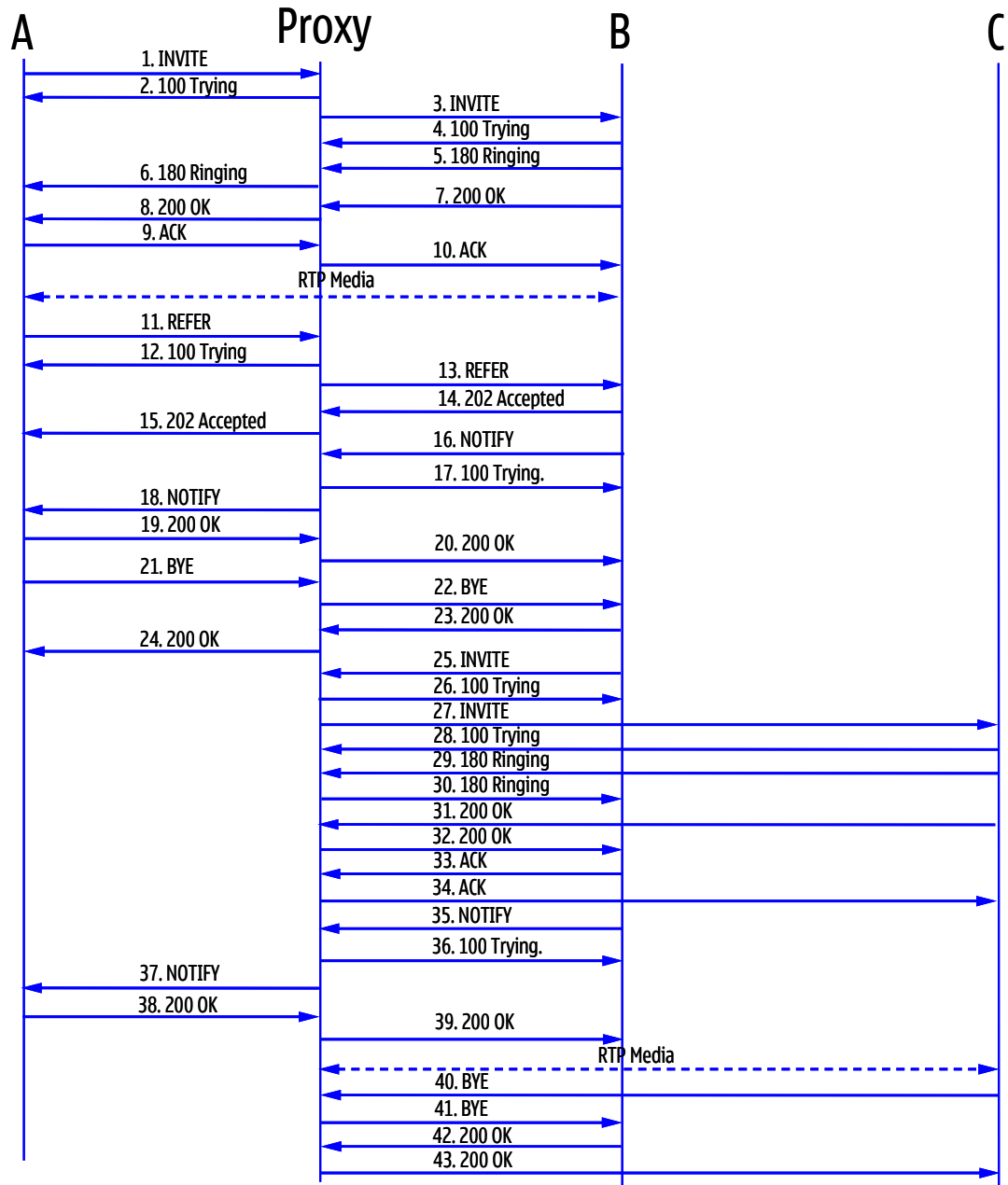

Step	Action	Description
1 - A makes a call to B	INVITE	A sends an INVITE request to the proxy.
2	100 Trying	The proxy sends a 100 response to A to acknowledge that the INVITE request has been received by the proxy.
3	INVITE	The INVITE request is forwarded to B.
4	100 Trying	B sends a 100 response to the proxy to acknowledge that the INVITE request has been received by B.

Step	Action	Description
5	180 Ringing	B sends a 180 response to the proxy to indicate that B is being alerted.
6	180 Ringing	The 180 response is forwarded to A.
7 – B answers the call	200 OK	B sends a 200 response to the proxy. This notifies the proxy that a connection has been established.
8	200 OK	The proxy forwards the 200 response to A.
9	ACK	A acknowledges the 200 response from the proxy.
10	ACK	The proxy forwards the acknowledgement to B.
11 – A transfers the call from B to C	REFER	A sends a REFER message request to the proxy.
12	100 Trying	The proxy sends a 100 response to A to acknowledge that the REFER request has been received by the proxy.
13	REFER	The proxy forwards the REFER request to the B phone.
14	202 Accepted	B accepts the transfer with a 202 response to the proxy.
15	202 Accepted	The proxy forwards the 202 response to A.
16 – B accepts the transfer	NOTIFY	B sends a NOTIFY request to the proxy that the transfer can be activated.
17	100 Trying	The proxy sends a 100 response to B to acknowledge that the NOTIFY request has been received by the proxy.
18	NOTIFY	The proxy forwards the NOTIFY request to A.
19	200 OK	A sends a 200 response to the proxy. This notifies the proxy that the call is going to be transferred.
20	200 OK	The proxy forwards the 200 response to B.
21 – Call between A and B is terminated	BYE	A disconnects the call to B by sending a BYE request to the proxy.
22	BYE	The proxy forwards the BYE request to B.
23	200 OK	B sends a 200 response to the proxy that it has disconnected the call.
24	200 OK	The proxy forwards the 200 response to A.
25	INVITE	B sends an INVITE request to the proxy.
26	100 Trying	The proxy sends a 100 response to B to acknowledge that the INVITE request has been received by the proxy.
27	INVITE	The INVITE message request is forwarded to C.
28	100 Trying	C sends a 100 response to the proxy to acknowledge that the INVITE request has been received by C.
29	180 Ringing	C sends a 180 response to the proxy to indicate that C is being alerted.

Step	Action	Description
30	180 Ringing	The 180 response is forwarded to B.
31	200 OK	C sends a 200 OK message to the proxy. This notifies the proxy that a connection has been made.
32	200 OK	The proxy forwards the 200 response to B.
33	ACK	B acknowledges the 200 response from the proxy.
34	ACK	The proxy forwards the acknowledgement to C.
35	NOTIFY	B sends a NOTIFY request to the proxy that the transfer has been done.
36	100 Trying	The proxy sends a 100 response to B to acknowledge that the NOTIFY request has been received by proxy.
37	NOTIFY	The proxy forwards the NOTIFY request to A.
38	200 OK	A sends a 200 response to the proxy. This notifies the proxy that the transfer has been finished.
39	200 OK	The proxy forwards the 200 response to B.
40 –C terminates the call	BYE	C sends a BYE request to the proxy.
41	BYE	The proxy forwards the BYE request to B.
42	200 OK	B sends a 200 response to the proxy. The 200 response notifies the proxy that B has received the BYE request.
43	200 OK	The proxy forwards the 200 OK response to C.

Table 8: Unattended call transfer

3.5 Attended transfer

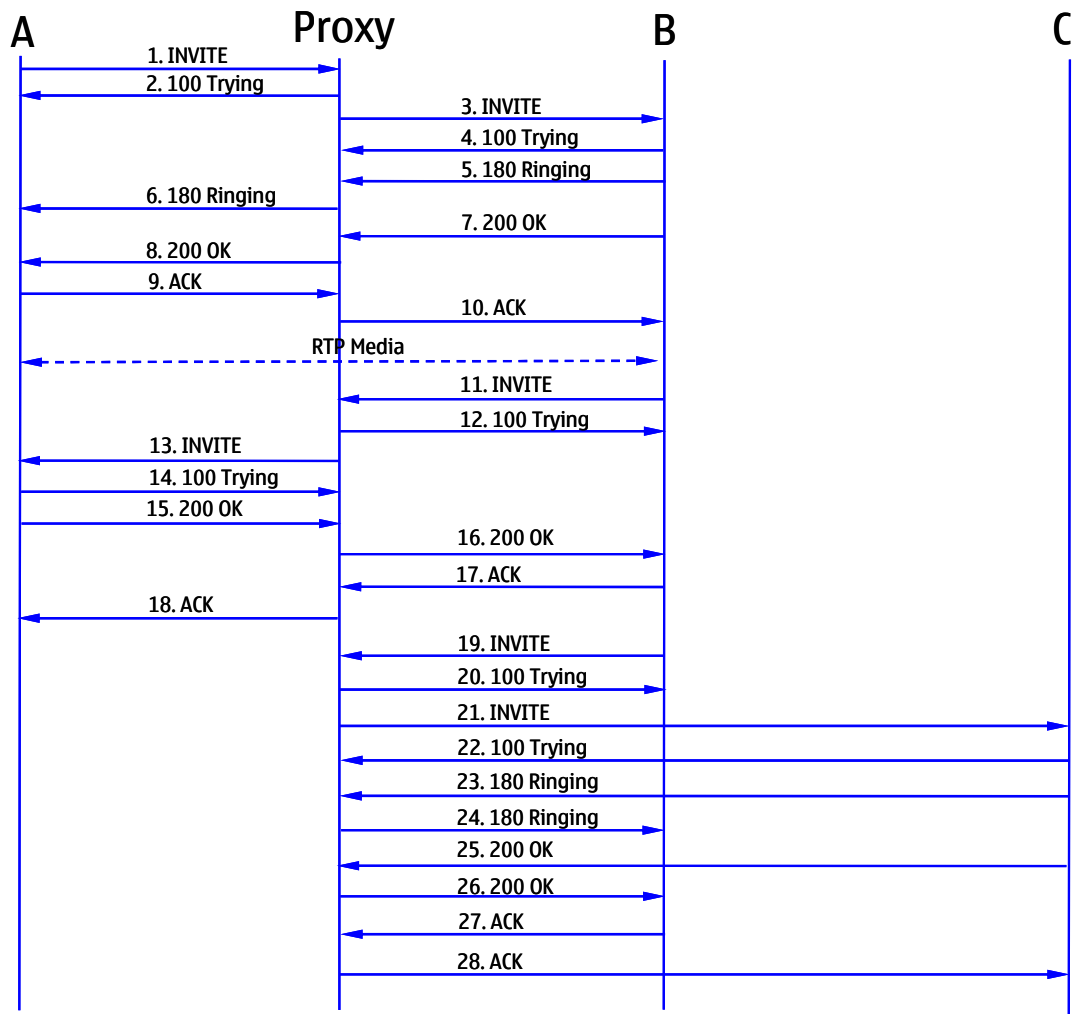

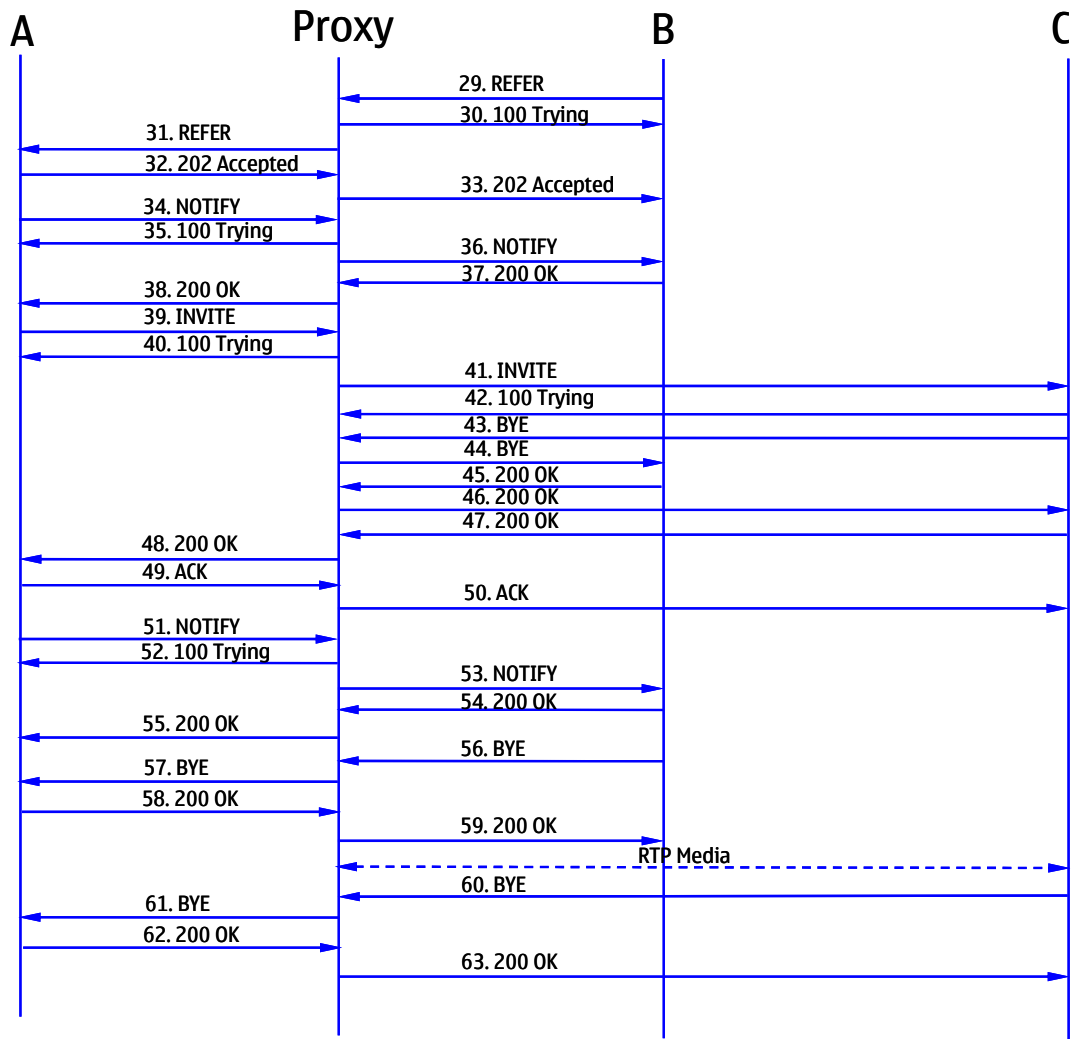

Step	Action	Description
1 - A makes a call to B	INVITE	A sends an INVITE request to the proxy.
2	100 Trying	The proxy sends a 100 response to A to acknowledge that the INVITE request has been received by the proxy.
3	INVITE	The INVITE request is forwarded to B.
4	100 Trying	B sends a 100 response to the proxy to acknowledge that the INVITE request has been received by B.
5	180 Ringing	B sends a 180 response to the proxy to indicate that B is being alerted.
6	180 Ringing	The 180 response is forwarded to A.
7 – B answers the call	200 OK	B sends a 200 response to the proxy. This notifies the proxy that a connection has been established.
8	200 OK	The proxy forwards the 200 response to A.
9	ACK	A acknowledges the 200 response from the proxy.
10	ACK	The proxy forwards the acknowledgement to B.

Step	Action	Description
11 – B puts A on hold	INVITE	B sends a new INVITE request to the proxy with the order to put the call on hold.
12	100 Trying	The proxy sends a 100 response to B to acknowledge that the INVITE request has been received by the proxy.
13	INVITE	The proxy forwards the INVITE request to A.
14	100 Trying	A sends a 100 response to the proxy to acknowledge that the INVITE request has been received by A.
15	200 OK	A sends a 200 response to the proxy.
16	200 OK	The proxy forwards the 200 response to B.
17	ACK	B acknowledges the 200 response from the proxy.
18	ACK	The proxy forwards the acknowledgement to A.
19 – B makes a call to C	INVITE	B sends an INVITE request to the proxy.
20	100 Trying	The proxy sends a 100 response to B to acknowledge that the INVITE request has been received by the proxy.
21	INVITE	The INVITE request is forwarded to C.
22	100 Trying	C sends a 100 response to the proxy to acknowledge that the INVITE request has been received by C.
23	180 Ringing	C sends a 180 response to the proxy to indicate that C is being alerted
24	180 Ringing	The 180 response is forwarded to B.
25 – C answers the call	200 OK	C sends a 200 response to the proxy. This notifies the proxy that a connection has been established.
26	200 OK	The proxy forwards the 200 response to B.
27	ACK	B acknowledges the 200 response from the proxy.
28	ACK	The proxy forwards the acknowledgement to C.
29 – B transfers the call from A to C	REFER	B sends a REFER message request to the proxy.
30	100 Trying	The proxy sends a 100 response to A to acknowledge that the REFER request has been received by the proxy.
31	REFER	The proxy forwards the REFER request to A phone.
32	202 Accepted	A accepts the transfer with a 202 response to the proxy.
33	202 Accepted	The proxy forwards the 202 response to B.
34 – A accepts the transfer	NOTIFY	A sends a NOTIFY request to the proxy that the transfer can be activated.
35	100 Trying	The proxy sends a 100 response to A to acknowledge that the NOTIFY request has been received by the proxy.

Step	Action	Description
36	NOTIFY	The proxy forwards the NOTIFY request to B.
37	200 OK	B sends a 200 response to the proxy. This notifies the proxy that the call is going to be transferred.
38	200 OK	The proxy forwards the 200 response to A.
39	INVITE	A sends an INVITE request to the proxy.
40	100 Trying	The proxy sends a 100 response to A to acknowledge that the INVITE request has been received by the proxy.
41	INVITE	An INVITE request is forwarded to C.
42	100 Trying	C sends a 100 response to the proxy to acknowledge that the INVITE request has been received by C.
43 – <i>Call between B and C is terminated</i>	BYE	C sends a BYE request to the proxy to end the call.
44	BYE	The proxy forwards the BYE request to B.
45	200 OK	B sends a 200 response to the proxy. The 200 response notifies the proxy that B has received the BYE request.
46	200 OK	The proxy forwards the 200 OK response to C. The call session is terminated.
47	200 OK	C sends the 200 OK message to the proxy. This notifies the proxy that a connection has been made.
48	200 OK	The proxy forwards the 200 response to A.
49	ACK	A acknowledges the 200 response from the proxy.
50	ACK	The proxy forwards the acknowledgement to C.
51	NOTIFY	A sends a NOTIFY request to the proxy that the transfer has been done.
52	100 Trying	The proxy sends a 100 response to A to acknowledge that the NOTIFY request has been received by the proxy.
53	NOTIFY	The proxy forwards the NOTIFY request to B.
54	200 OK	B sends a 200 response to the proxy. This notifies the proxy that the transfer has been finished.
55	200 OK	The proxy forwards the 200 response to A.
56 – <i>Call between B and A is terminated</i>	BYE	B sends a BYE request to the proxy.
57	BYE	The proxy forwards the BYE request to A.
58	200 OK	A sends a 200 response to the proxy. The 200 response notifies the proxy that A has received the BYE request.
59	200 OK	The proxy forwards the 200 OK response to B.
60 – C terminates the call	BYE	C sends a BYE request to the proxy.

Step	Action	Description
61	BYE	The proxy forwards the BYE request to A.
62	200 OK	A sends a 200 response to the proxy. The 200 response notifies the proxy that A has received the BYE request.
63	200 OK	The proxy forwards the 200 OK response to C.

Table 9: Attended call transfer

3.6 Call forwarding – No answer

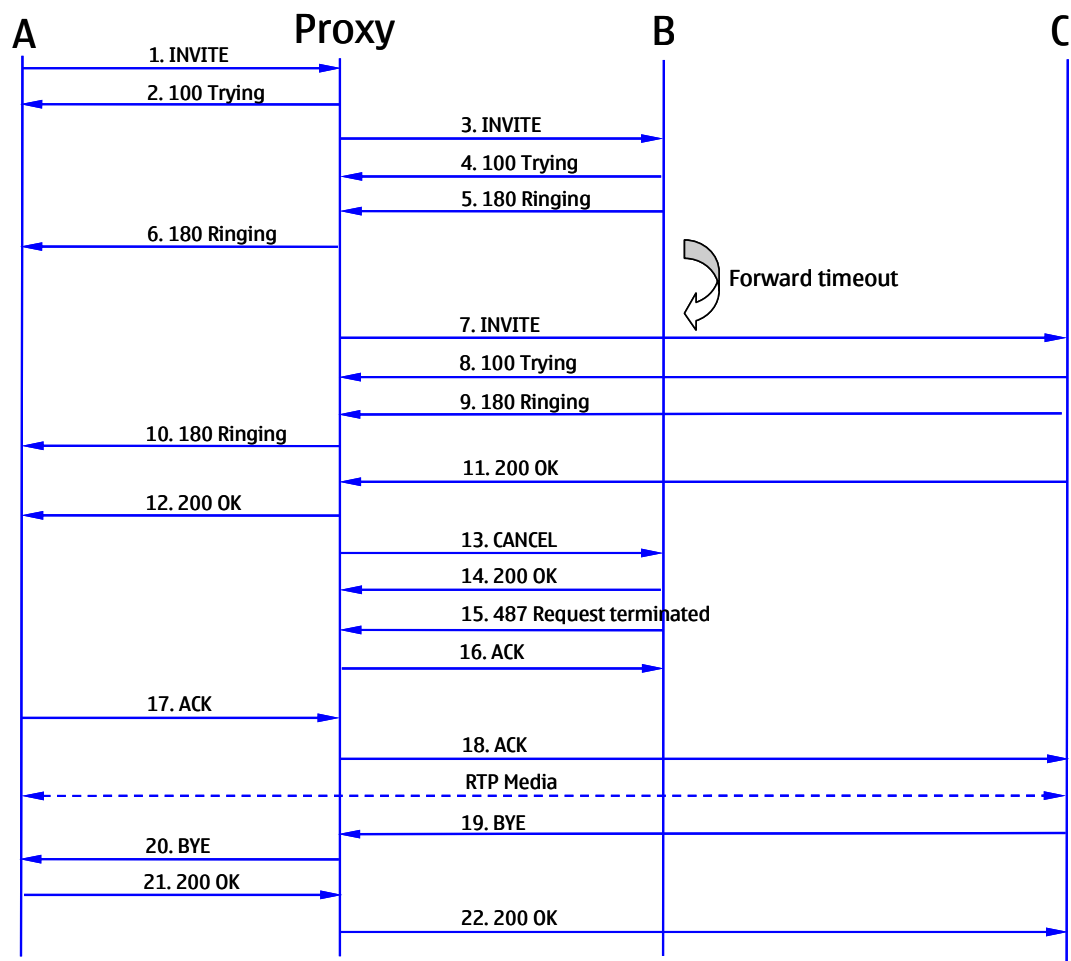

Step	Action	Description
1 - A makes a call to B	INVITE	A sends an INVITE request to the proxy.
2	100 Trying	The proxy sends a 100 response to A to acknowledge that the INVITE request has been received by the proxy.
3	INVITE	The INVITE request is forwarded to B.
4	100 Trying	B sends a 100 response to the proxy to acknowledge that the INVITE request has been received by B.

Step	Action	Description
5	180 Ringing	B sends a 180 response to the proxy to indicate that B is being alerted.
6	180 Ringing	The 180 response is forwarded to A.
7 – <i>Call is forwarded</i>	INVITE	An INVITE request is forwarded to C.
8	100 Trying	C sends a 100 response to the proxy to acknowledge that the INVITE request has been received by C.
9	180 Ringing	C sends a 180 response to the proxy to indicate that C is being alerted.
10	180 Ringing	The 180 response is forwarded to A.
11 – C answers the call	200 OK	C sends a 200 response to the proxy. This notifies the proxy that a connection has been established.
12	200 OK	The proxy forwards the 200 response to A.
13	CANCEL	The proxy sends a CANCEL request to B to cancel the INVITE.
14	200 OK	B sends a 200 response to the proxy. The 200 response notifies the proxy that B has received the CANCEL request.
15	487 Request terminated	B cancels the INVITE request by sending a 487 response to the proxy.
16	ACK	The proxy sends the acknowledgement of the 487 response to B.
17	ACK	A acknowledges the 200 response from the proxy.
18	ACK	The proxy forwards the acknowledgement to C.
19 –C terminates the call	BYE	C sends a BYE request to the proxy.
20	BYE	The proxy forwards the BYE request to A.
21	200 OK	A sends a 200 response to the proxy. The 200 response notifies the proxy that A has received the BYE request.
22	200 OK	The proxy forwards the 200 OK response to C.

Table 10: Call forwarded – No answer

3.7 Call forwarding – Busy

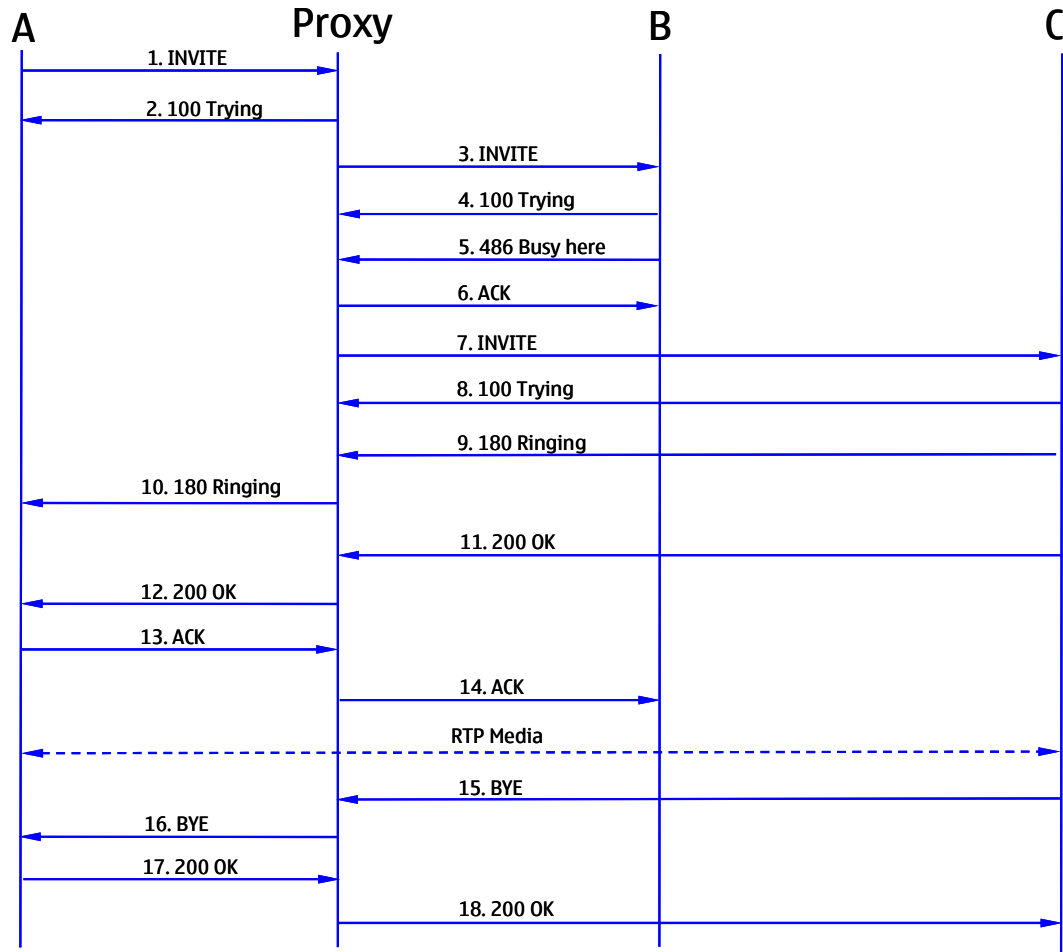

Step	Action	Description
1 - A makes a call to B	INVITE	A sends an INVITE request to the proxy.
2	100 Trying	The proxy sends a 100 response to A to acknowledge that the INVITE request has been received by the proxy.
3	INVITE	The INVITE request is forwarded to B.
4	100 Trying	B sends a 100 response to the proxy to acknowledge that the INVITE request has been received by B.
5	486 Busy here	
6	ACK	
7 – Call is forwarded	INVITE	The INVITE request is forwarded to C.
8	100 Trying	C sends a 100 response to the proxy to acknowledge that the INVITE request has been received by C.
9	180 Ringing	C sends a 180 response to the proxy to indicate that C is being alerted.
10	180 Ringing	The 180 response is forwarded to A.

Step	Action	Description
11 – C answers the call	200 OK	C sends a 200 response to the proxy. This notifies the proxy that a connection has been established.
12	200 OK	The proxy forwards the 200 response to A.
13	ACK	A acknowledges the 200 response from the proxy.
14	ACK	The proxy forwards the acknowledgement to C.
15 –C terminates the call	BYE	C sends a BYE request to the proxy.
16	BYE	The proxy forwards the BYE request to A.
17	200 OK	A sends a 200 response to the proxy. The 200 response notifies the proxy that A has received the BYE request.
18	200 OK	The proxy forwards the 200 OK response to C.

Table 11: Call forwarded - Busy

3.8 Call forwarding – Busy (call waiting enabled)

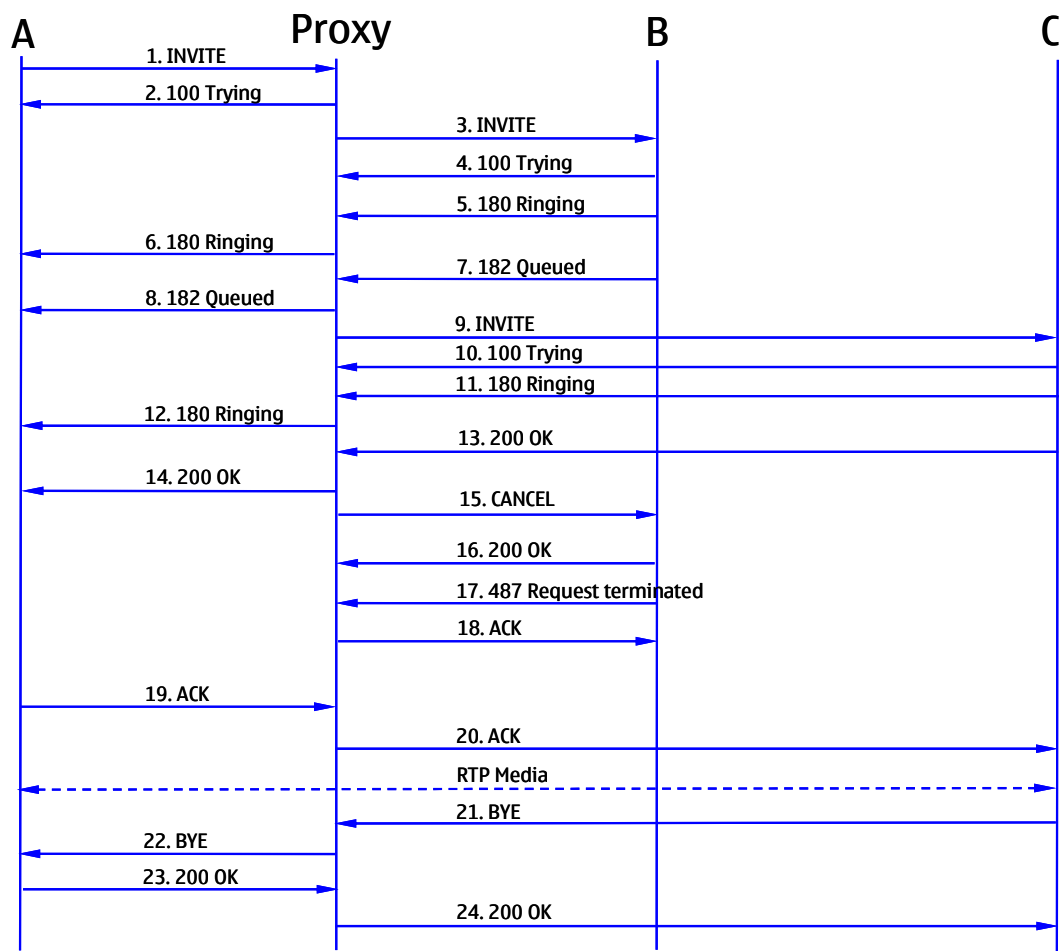

Step	Action	Description
1 - A makes a call to B	INVITE	A sends an INVITE request to the proxy.
2	100 Trying	The proxy sends a 100 response to A to acknowledge that the INVITE request has been received by the proxy.
3	INVITE	The INVITE request is forwarded to B.
4	100 Trying	B sends a 100 response to the proxy to acknowledge that the INVITE request has been received by B.
5	180 Ringing	B sends a 180 response to the proxy to indicate that B is being alerted.
6	180 Ringing	The 180 response is forwarded to A.
7	182 Queued	B sends a 182 response to the proxy to indicate that B is busy and A is in queue.
8	182 Queued	The 182 response is forwarded to A.
9 – <i>Call is forwarded</i>	INVITE	An INVITE request is forwarded to C.
10	100 Trying	C sends a 100 response to the proxy to acknowledge that the INVITE request has been received by C.
11	180 Ringing	C sends a 180 response to the proxy to indicate that C is being alerted.
12	180 Ringing	The 180 response is forwarded to A.
13 – C answers the call	200 OK	C sends a 200 response to the proxy. This notifies the proxy that a connection has been established.
14	200 OK	The proxy forwards the 200 response to A.
15	CANCEL	The proxy sends a CANCEL request to B to cancel the INVITE.
16	200 OK	B sends a 200 response to the proxy. The 200 response notifies the proxy that B has received the CANCEL request.
17	487 Request terminated	B cancels the INVITE request by sending a 487 response to the proxy.
18	ACK	The proxy sends the acknowledgement of the 487 response to B.
19	ACK	A acknowledges the 200 response from the proxy.
20	ACK	The proxy forwards the acknowledgement to C.
21 –C terminates the call	BYE	C sends a BYE request to the proxy.
22	BYE	The proxy forwards the BYE request to A.
23	200 OK	A sends a 200 response to the proxy. The 200 response notifies proxy that A has received the BYE request.
24	200 OK	The proxy forwards the 200 OK response to C.

Table 12: Call forwarded – Busy (call waiting enabled)

3.9 Register with NAT traversal using STUN

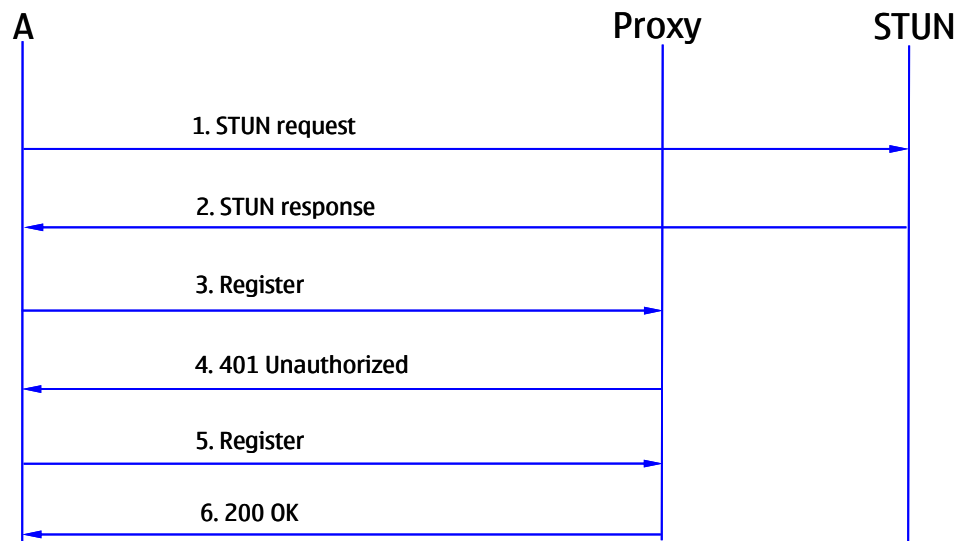

Step	Action	Description
1	STUN request	A makes a STUN request to the STUN server.
2	STUN response	The STUN server responds with a STUN response.
3	Register	A sends a REGISTER request to the proxy with the IP address acquired by the STUN request.
4	401 Unauthorized	The proxy challenges A with a 401 response to submit the credentials.
5	Register	A resends the REGISTER request with credentials.
6	200 OK	The proxy responds with a 200 response to indicate that A is now registered in the proxy.

Table 13: Register with NAT traversal using STUN

3.10 Call with NAT traversal using STUN

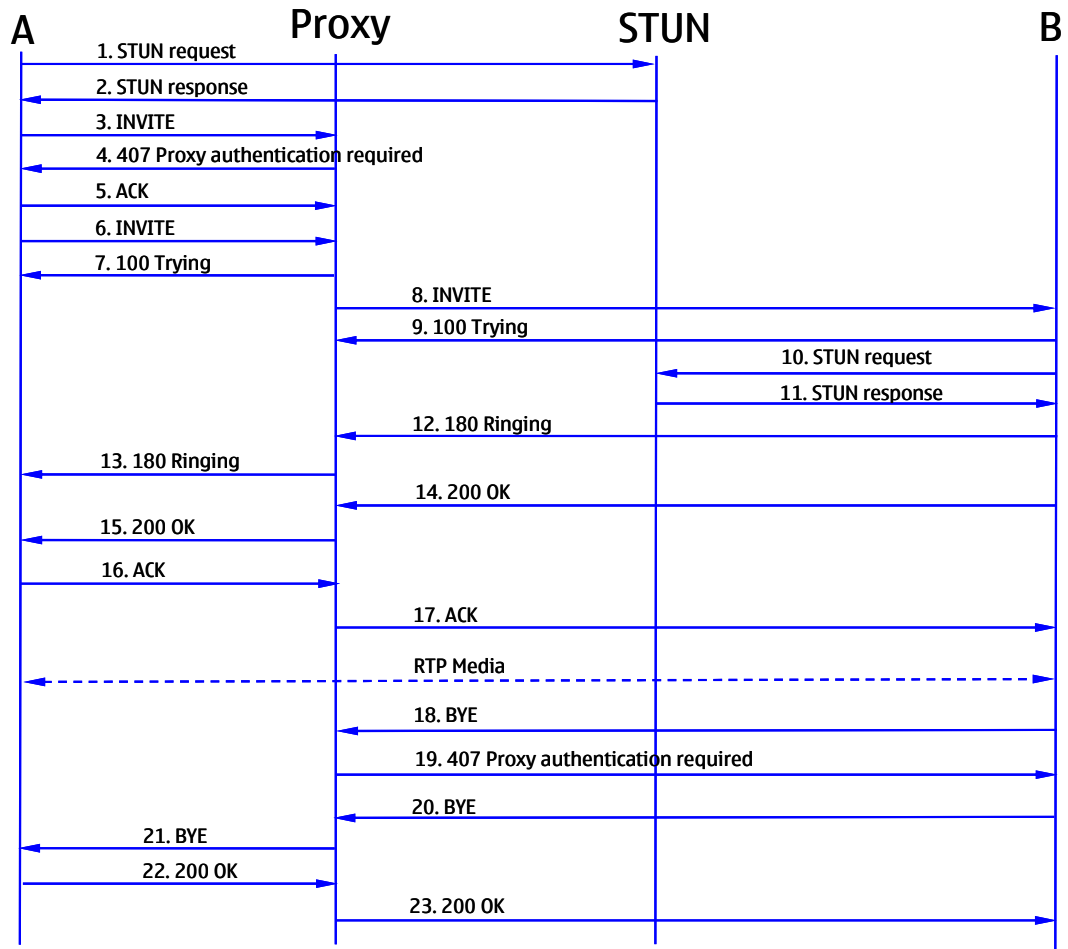

Step	Action	Description
1	STUN request	A makes a STUN request to the STUN server.
2	STUN response	The STUN server responds with a STUN response.
3 – A makes a call to B	INVITE	A sends an INVITE request to the proxy with the media address acquired by the STUN request.
4	407 Proxy authentication required	The proxy challenges A with a 407 response to submit the credentials.
5	ACK	A acknowledges the 407 response from the proxy.
6	INVITE	A sends an INVITE request with credentials to the proxy.
7	100 Trying	The proxy sends a 100 response to A to acknowledge that the INVITE request has been received by the proxy.
8	INVITE	The INVITE request is forwarded to B.
9	100 Trying	B sends a 100 response to the proxy to acknowledge that the INVITE request has been received by B.

Step	Action	Description
10	STUN request	B makes a STUN request to the STUN server.
11	STUN response	The STUN server responds with a STUN response.
12	180 Ringing	B sends a 180 response to the proxy to indicate that B is being alerted.
13	180 Ringing	The 180 response is forwarded to A.
14 – B answers the call	200 OK	B sends a 200 response to the proxy. This notifies the proxy that a connection has been established.
15	200 OK	The proxy forwards the 200 response to A.
16	ACK	A acknowledges the 200 response from the proxy.
17	ACK	The proxy forwards the acknowledgement to B.
18 –B terminates the call	BYE	B sends a BYE request to the proxy.
19	407 Proxy authentication required	The proxy challenges B with a 407 response to submit the credentials.
20	BYE	B sends the BYE request with credentials to the proxy.
21	BYE	The proxy forwards the BYE request to A.
22	200 OK	A sends a 200 response to the proxy. The 200 response notifies the proxy that A has received the BYE request.
23	200 OK	The proxy forwards the 200 OK response to B.

Table 14: Call with NAT traversal using STUN

4 Failed call situations

4.1 Not found

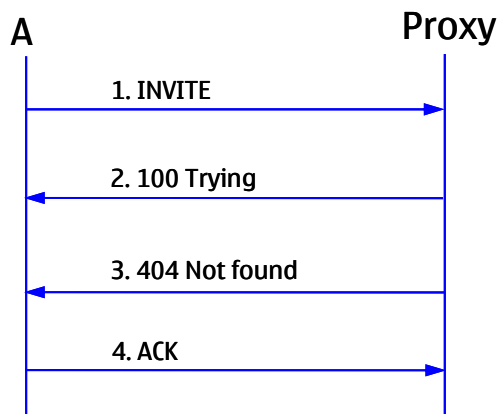

Step	Action	Description
1 – A makes a call to B	INVITE	The caller makes a call to B. The phone sends an INVITE request to the proxy.
2	100 Trying	The proxy sends a 100 response to A to acknowledge that the INVITE request has been received by the proxy.
3 – B is not registered in the proxy	404 Not Found	The proxy sends a 404 response to A to indicate that B is not registered in the proxy.
4	ACK	A acknowledges the 404 response to the proxy.

Table 15: Not found

4.2 Busy here

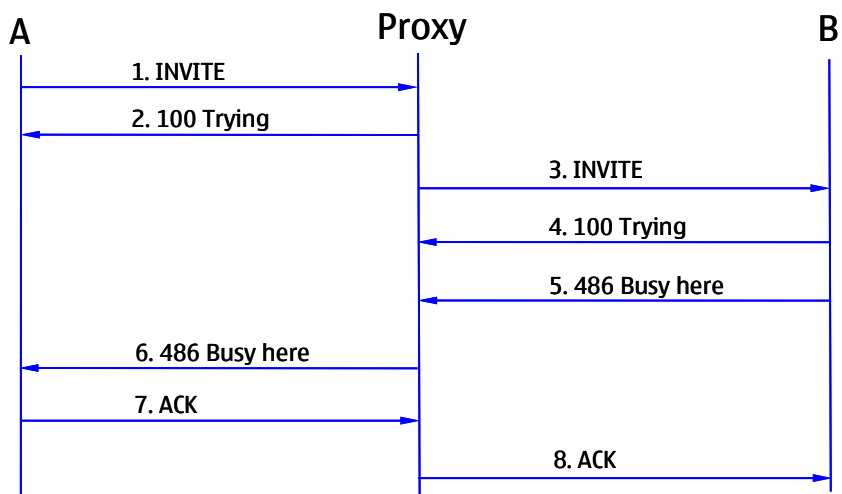

Step	Action	Description
1 – A makes a call to B	INVITE	A sends an INVITE request to the proxy.
2	100 Trying	The proxy sends a 100 response to A to acknowledge that the INVITE request is proceeding.
3	INVITE	The INVITE request is forwarded to B.
4	100 Trying	B sends a 100 response to the proxy to acknowledge that the INVITE request has been received by B.
5 – B is having another call or has Do Not Disturb enabled	486 Busy here	B sends a 486 response to the proxy to inform that it cannot answer the call or that it has Do Not Disturb enabled.
6	486 Busy here	The proxy forwards the 486 response to A.
7	ACK	A sends the acknowledgement of the response to the proxy.
8	ACK	The proxy forwards the acknowledgement to B.

Table 16: Busy here

4.3 Callee does not answer

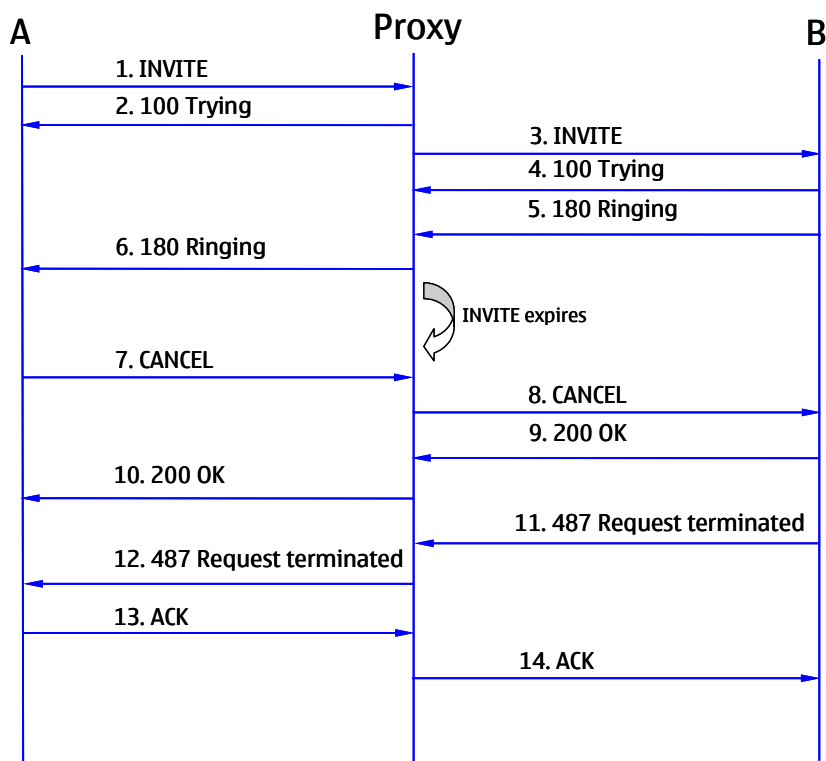

Step	Action	Description
1 - A makes a call to B	INVITE	A sends an INVITE request to the proxy.
2	100 Trying	The proxy sends a 100 response to A to acknowledge that the INVITE request is proceeding.

Step	Action	Description
3	INVITE	The INVITE request is forwarded to B.
4	100 Trying	B sends a 100 response to the proxy to acknowledge that the INVITE request has been received by B.
5	180 Ringing	B sends a 180 response to the proxy to indicate that B is being alerted.
6	180 Ringing	The 180 response is forwarded to A.
7 – INVITE expires	CANCEL	A sends a CANCEL request to the proxy to cancel the INVITE.
8	CANCEL	The proxy forwards the CANCEL request to B.
9	200 OK	B sends a 200 response to the proxy. This notifies the proxy that the CANCEL request has been received.
10	200 OK	The proxy forwards the 200 response to A.
11	487 Request terminated	B cancels the INVITE request by sending a 487 response to the proxy.
12	487 Request terminated	The proxy forwards the 487 response to A.
13	ACK	A sends the acknowledgement of the response to the proxy.
14	ACK	The proxy forwards the acknowledgement to B.

Table 17: Callee does not answer

4.4 Anonymous call barring

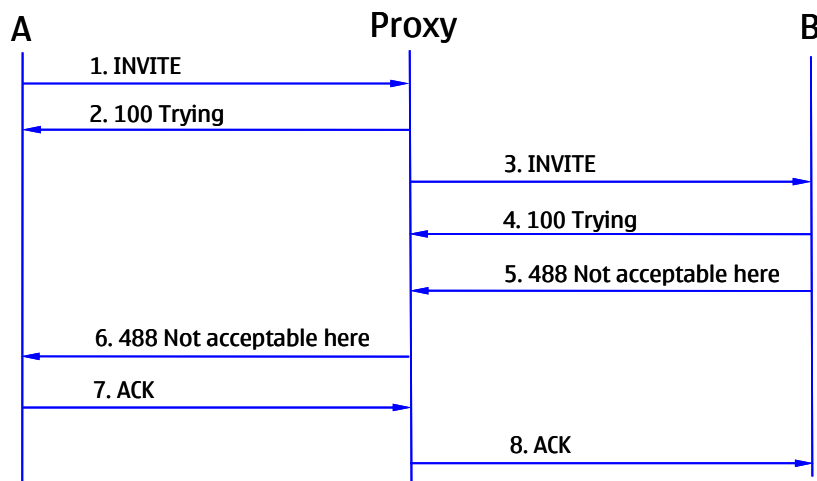

Step	Action	Description
1 – A makes a call to B	INVITE	A sends an INVITE request to the proxy.
2	100 Trying	The proxy sends a 100 response to A to acknowledge that the INVITE request is proceeding.

Step	Action	Description
3	INVITE	The INVITE request is forwarded to B.
4	100 Trying	B sends a 100 response to the proxy to acknowledge that the INVITE request has been received by B.
5 – B is barring anonymous callers	488 Not acceptable here	B sends a 488 response to the proxy to inform that it is barring anonymous callers.
6	488 Not acceptable here	The proxy forwards the 488 response to A.
7	ACK	A sends the acknowledgement of the response to the proxy.
8	ACK	The proxy forwards the acknowledgement to B.

Table 18: Anonymous call barring

4.5 Request timeout

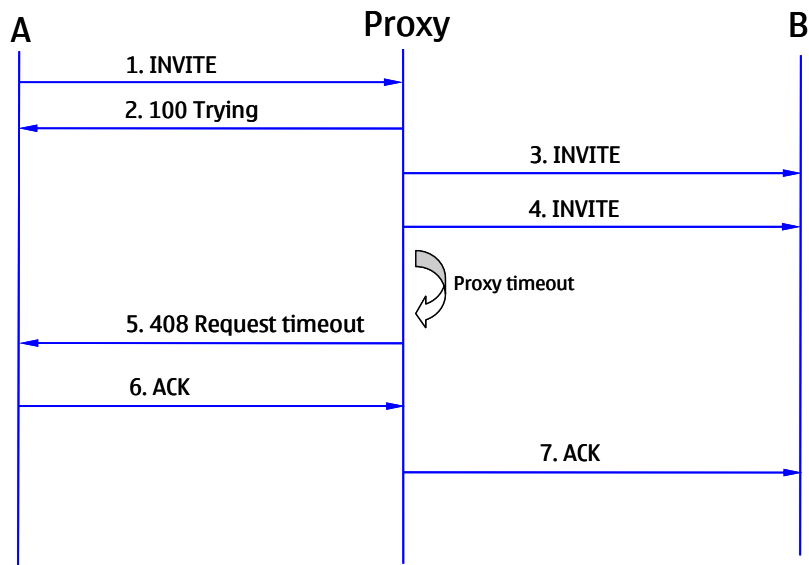

Step	Action	Description
1 – A makes a call to B	INVITE	A sends an INVITE request to the proxy.
2	100 Trying	The proxy sends a 100 response to A to acknowledge that the INVITE has been received by the proxy.
3	INVITE	The INVITE request is forwarded to B.
4	INVITE	The INVITE request is reforwarded to B.
5	408 Request timeout	The proxy sends a 408 response after that there is no answer from B.
6	ACK	A acknowledges that it has received the 408 response from the proxy.
7	ACK	The proxy forwards the acknowledgement to B.

Table 19: Request timeout

5 Terms and abbreviations

Term or abbreviation	Meaning
Callee (B, C)	The party that receives an INVITE request for the purpose of establishing a new session. A callee retains this role from the time it receives the INVITE until the termination of the dialog established by that INVITE.
Caller (A)	The party initiating a session (and dialog) with an INVITE request. A caller retains this role from the time it sends the initial INVITE that established a dialog until the termination of that dialog.
Client	A client is any network element that sends SIP requests and receives SIP responses. A client may or may not interact directly with a human user. User agent clients and proxies are clients.
Location Service	A location service is used by a SIP redirect or proxy server to obtain information about the possible location(s) of a callee.
Proxy, Proxy Server	An intermediary entity that acts as both a server and a client for the purpose of making requests on behalf of other clients. A proxy server primarily plays the role of routing which means its job is to ensure that a request is sent to another entity 'closer' to the targeted user. Proxies are also useful for enforcing policy (for example, making sure a user is allowed to make a call). A proxy interprets and, if necessary, rewrites specific parts of a request message before forwarding it.
Redirect Server	A redirect server is a user agent server that generates 3xx responses to requests it receives, directing the client to contact an alternate set of URIs.
Registrar	A registrar is a server that accepts REGISTER requests and places the information it receives in those requests into location service for the domain it handles.
Request	A SIP message sent from a client to a server for the purpose of invoking a particular operation.
Response	A SIP message sent from a server to a client for indicating the status of a request sent from the client to the server.
Server	A server is a network element that receives requests in order to service them and sends back responses to those requests. Proxies, user agent servers, redirect servers, and registrars are examples of servers.
STUN	Simple traversal of user datagram protocol through network address translators.
STUN Server	A STUN server is an entity that receives STUN requests and sends STUN responses.
User Agent Client (UAC)	A user agent client is a logical entity that creates a new request and then uses the client transaction state machinery to send it. The role of the UAC lasts only for the duration of that transaction. So, if a piece of software initiates a request, it acts as a UAC for the duration of that transaction. If it receives a request later, it assumes the role of a user agent server for the processing of that transaction.
User Agent Server (UAS)	A user agent server is a logical entity that generates a response to a SIP request. The response accepts, rejects, or redirects the request. This role lasts only for the duration of that transaction. So, if a piece of software responds to a request, it acts as a UAS for the duration of that transaction. If it generates a request later, it assumes the role of a user agent client for the processing of that transaction.

Note: In this document, proxy, location, and registrar servers are combined into a single proxy server.

Evaluate this resource

Please spare a moment to help us improve documentation quality and recognize the resources you find most valuable, by [rating this resource](#).