

OMA DM: Management Object for SIP

Version 1.2; March 28, 2007

OMA Device Management

NOKIA

Copyright © 2006-2007 Nokia Corporation. All rights reserved.

Nokia and Nokia Connecting People are registered trademarks of Nokia Corporation. Java and all Java-based marks are trademarks or registered trademarks of Sun Microsystems, Inc. Other product and company names mentioned herein may be trademarks or trade names of their respective owners.

Disclaimer

The information in this document is provided “as is,” with no warranties whatsoever, including any warranty of merchantability, fitness for any particular purpose, or any warranty otherwise arising out of any proposal, specification, or sample. Furthermore, information provided in this document is preliminary, and may be changed substantially prior to final release. This document is provided for informational purposes only.

Nokia Corporation disclaims all liability, including liability for infringement of any proprietary rights, relating to implementation of information presented in this document. Nokia Corporation does not warrant or represent that such use will not infringe such rights.

Nokia Corporation retains the right to make changes to this specification at any time, without notice.

License

A license is hereby granted to download and print a copy of this specification for personal use only. No other license to any other intellectual property rights is granted herein.

Contents

1	Introduction.....	6
1.1	Notation	6
2	Session Initiation Protocol (SIP) management object v1.0 description	8
2.1	Graphical representation.....	9
2.2	Node descriptions	10
2.2.1	./SIP.....	10
2.2.2	./SIP/<X>/	10
2.2.3	./SIP/<X>/SIPId	10
2.2.4	./SIP/<X>/Name	10
2.2.5	./SIP/<X>/ProfileType.....	10
2.2.6	./SIP/<X>/AddressOfRecord.....	11
2.2.7	./SIP/<X>/Default.....	11
2.2.8	./SIP/<X>/LooseRouting	11
2.2.9	./SIP/<X>/EnableSecurityNegotiation.....	11
2.2.10	./SIP/<X>/EnableSignalCompression.....	12
2.2.11	./SIP/<X>/EnableAutoRegistration	12
2.2.12	./SIP/<X>/ProfileLock	12
2.2.13	./SIP/<X>/PrefConRef.....	12
2.2.14	./SIP/<X>/OutboundProxy	13
2.2.15	./SIP/<X>/OutboundProxy/Host.....	13
2.2.16	./SIP/<X>/OutboundProxy/Port	13
2.2.17	./SIP/<X>/OutboundProxy/Transport	13
2.2.18	./SIP/<X>/OutboundProxy/Username.....	13
2.2.19	./SIP/<X>/OutboundProxy/Passwd.....	14
2.2.20	./SIP/<X>/OutboundProxy/Realm	14
2.2.21	./SIP/<X>/RegistrarServer	14
2.2.22	./SIP/<X>/RegistrarServer/Host	14
2.2.23	./SIP/<X>/RegistrarServer/Port.....	14
2.2.24	./SIP/<X>/RegistrarServer/Transport.....	15
2.2.25	./SIP/<X>/RegistrarServer/Username	15
2.2.26	./SIP/<X>/RegistrarServer/PrivateIdentity.....	15
2.2.27	./SIP/<X>/RegistrarServer/Passwd	15
2.2.28	./SIP/<X>/RegistrarServer/Realm.....	16
3	Terms and abbreviations.....	17
4	References	18

5	Evaluate this resource	19
---	------------------------------	----

Change history

July 7, 2006	Version 1.0	Initial document release
October 27, 2006	Version 1.1	Minor updates throughout the document.
March 28, 2007	Version 1.2	Added more information to OutboundProxy/Host, OutboundProxy/Realm, and RegistrarServer/Realm leaf objects.

1 Introduction

This document defines the SIP Management Object v1.0 settings format for Open Mobile Alliance (OMA) Device Management (DM) usage. The definition of the parameter settings formats consists of tree structure, instance identifiers, and a detailed description of the management tree.

This document is a Nokia interpretation of the OMA Device Management specification. The intent of the document is to explain the organization of the parameters associated with this functionality.

1.1 Notation

This document uses the notation shown in Figure 1 to describe the DM management object tree model and parameters.

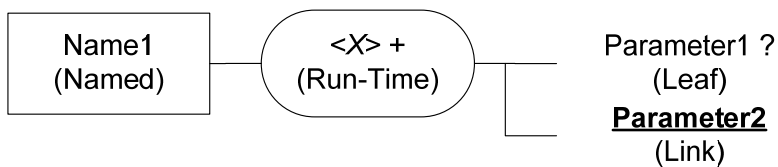

Figure 1: Notation

Named parent object

The name of the parent object is fixed. If the parent object's occurrence is One, the object's scope is permanent and cannot be deleted. If the parent object's occurrence is ZeroOrOne, the object's scope is dynamic and can be created and deleted at run time by the Management Server.

Run-time object

Run-time objects can be created and deleted at run time by the Management Server. Run-time object's scope is dynamic. Run-time objects in the text are represented by an <X> notation, where <X> represents the node's instance identifier that will be generated dynamically and can have any alphanumeric characters as a value.

Leaf object

Management objects without any children are called leaf objects. The Description Framework Type for leaf objects in this document is *text/plain*.

Link object

A link object is a type of leaf object that has an absolute URI value pointing to another object in the management tree of the same device, that is, always starting from the root node.

The following characters are used in the management object tree diagram to indicate how many instances of a specific node the Management Authority is able to configure in the management object tree:

Character	Meaning
+	One or many occurrences; that is, at least one instance of the parameter needs to exist and be configured.

Character	Meaning
*	Zero or more occurrences.
?	Zero or one occurrence.
(None)	Occurrence is One; that is, the parameter needs to exist and be configured.

Table 1: Characters used in the management object tree diagram

More information about management tree, object descriptions, and property elements (Occurrence, Scope, Access Type, and Format) can be found from the *OMA Device Management Tree and Description* document [2].

2 Session Initiation Protocol (SIP) management object v1.0 description

This chapter defines the management object structure and identifiers needed when managing SIP services using OMA DM.

The management object identifier for SIP Management Object v1.0 is “com.s60/1.0/SIP”.

2.1 Graphical representation

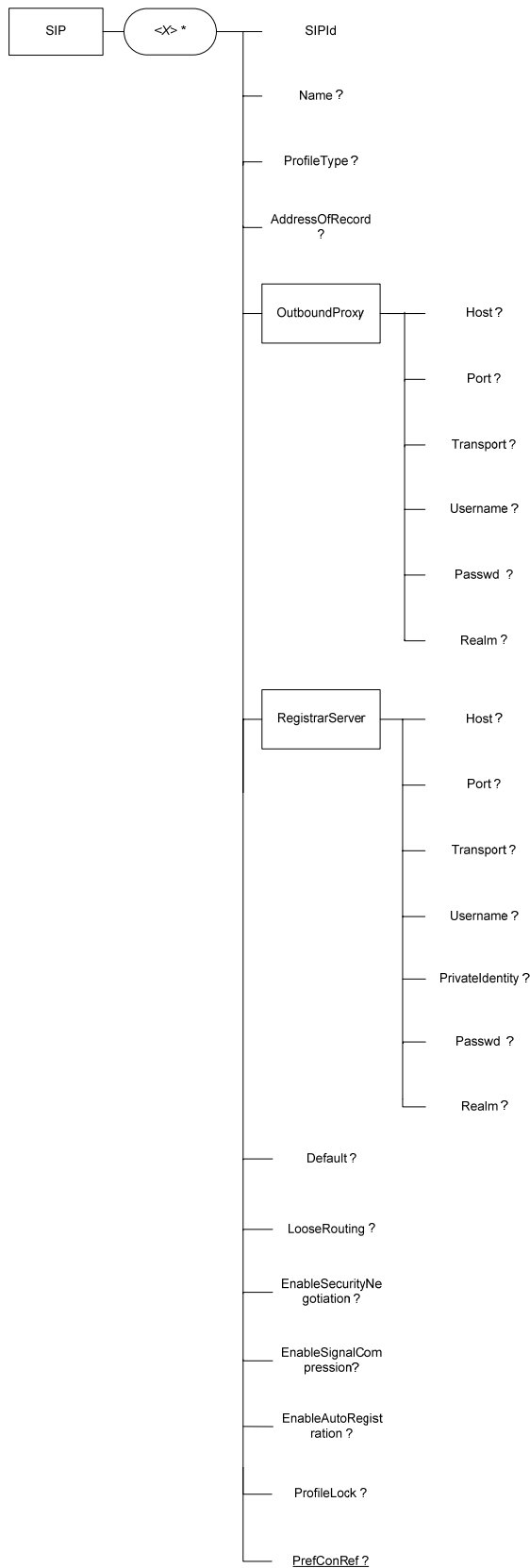

Figure 2. Graphical representation of the SIP management object

2.2 Node descriptions

2.2.1 ./SIP

Occurrence	Format	Access type
One	Node	Get

The SIP node is a parent to all SIP objects.

2.2.2 ./SIP/<X>/

Occurrence	Format	Access type
ZeroOrMore	Node	Add, Delete, Get, Replace

This run-time node acts as a placeholder for SIP profiles.

2.2.3 ./SIP/<X>/SIPId

Occurrence	Format	Access type
ZeroOrOne	Chr	Get

The SIPId leaf defines the ID for the SIP profile. If logical referencing is used, this ID can be used for linking other settings to SIP settings (for example, VoIP settings).

2.2.4 ./SIP/<X>/Name

Occurrence	Format	Access type
ZeroOrOne	Chr	Add, Get, Replace

The Name leaf defines the displayable provider name for the SIP profile.

2.2.5 ./SIP/<X>/ProfileType

Occurrence	Format	Access type
ZeroOrOne	Chr	Add, Get, Replace

The ProfileType leaf defines type of the SIP profile. Possible values for ProfileType are listed below:

Values	Description
IETF	Network compliant with IETF standards.
ims	Network compliant with 3GPP standards.

2.2.6 ./SIP/<X>/AddressOfRecord

Occurrence	Format	Access type
ZeroOrOne	Chr	Add, Get, Replace

The AddressOfRecord leaf defines (IETF) Address-Of-Record / (IMS) Public User Identity. The value is SIP URI according to IETF RFC 3261. More information about URIs can be found in the document *Uniform Resource Identifiers (URI): Generic Syntax* [4].

2.2.7 ./SIP/<X>/Default

Occurrence	Format	Access type
ZeroOrOne	Bool	Add, Get, Replace

The Default leaf defines if the profile is used by default.

Values	Description
True	The profile is used as a default. Note: Other profiles are automatically set as not being default when setting one profile as the default.
False	The profile is not default.

2.2.8 ./SIP/<X>/LooseRouting

Occurrence	Format	Access type
ZeroOrOne	Bool	Add, Get, Replace

The LooseRouting leaf defines if the profile uses loose routing. Possible values are:

Values	Description
True	Loose routing is used.
False	Loose routing is not used.

2.2.9 ./SIP/<X>/EnableSecurityNegotiation

Occurrence	Format	Access type
ZeroOrOne	Bool	Add, Get, Replace

The EnableSecurityNegotiation leaf defines if the profile uses security negotiation. Possible values are:

Values	Description
True	Security negotiation enabled.
False	Security negotiation disabled.

2.2.10 ./SIP/<X>/EnableSignalCompression

Occurrence	Format	Access type
ZeroOrOne	Bool	Add, Get, Replace

The EnableSignalCompression leaf defines if the profile uses signal compression. Possible values are:

Values	Description
True	Signal compression enabled.
False	Signal compression disabled.

2.2.11 ./SIP/<X>/EnableAutoRegistration

Occurrence	Format	Access Type
ZeroOrOne	Bool	Add, Get, Replace

The EnableAutoRegistration leaf defines if the profile uses automatic registration. Possible values are:

Values	Description
True	Autoregistration enabled.
False	Autoregistration disabled.

2.2.12 ./SIP/<X>/ProfileLock

Occurrence	Format	Access Type
ZeroOrOne	Chr	Add, Get, Replace

The ProfileLock parameter is used to lock the profile. When profile lock is enabled, editing the profile from the UI is not possible.

Values	Description
True	Profile lock is enabled.
False	Profile lock is disabled.

2.2.13 ./SIP/<X>/PrefConRef

Occurrence	Format	Access Type
ZeroOrOne	Chr	Add, Get, Replace

The PrefConRef link is used to define the logical reference to connectivity information (AP) stored elsewhere in the management tree.

2.2.14 .SIP/<X>/OutboundProxy

Occurrence	Format	Access type
One	Node	Add, Get

Node for outbound proxy settings.

2.2.15 .SIP/<X>/OutboundProxy/Host

Occurrence	Format	Access type
ZeroOrOne	Chr	Add, Get, Replace

The Host leaf defines the address of the outbound proxy/P-CSCF. IPV4/6 address, domain, or FQDN. Note that if the Host leaf has value 0.0.0.0 the host is resolved using DHCP Option 120.

2.2.16 .SIP/<X>/OutboundProxy/Port

Occurrence	Format	Access type
ZeroOrOne	Int	Add, Get, Replace

The Port leaf defines the port number of the outbound proxy/P-CSCF. If the Host leaf is not presented as an IPv4/6 address and this leaf is defined, then the client will perform an A or AAAA record lookup and NAPTR and SRV record lookups are not performed (see the document *Session Initiation Protocol (SIP): Locating SIP Servers* (IETF RFC 3263) [5] for more information).

2.2.17 .SIP/<X>/OutboundProxy/Transport

Occurrence	Format	Access type
ZeroOrOne	Chr	Add, Get, Replace

The Transport leaf defines the transport protocol to be used between the terminal and outbound proxy/P-CSCF. If the Host leaf is not presented as an IPv4/6 address and this leaf is defined but the Port leaf is not defined, then the client will perform DNS SRV, A, and AAAA record lookup, but NAPTR record lookups are not performed (see the document *Session Initiation Protocol (SIP): Locating SIP Servers* (IETF RFC 3263) [5] for more information).

Values	Description
TCP	TCP is used as the transport protocol.
UDP	UDP is used as the transport protocol.
Auto	Transport protocol is automatic.

2.2.18 .SIP/<X>/OutboundProxy/Username

Occurrence	Format	Access type
ZeroOrOne	Chr	Add, Get, Replace

The Username leaf defines the username for outbound proxy/P-CSCF realm.

2.2.19 `./SIP/<X>/OutboundProxy/Passwd`

Occurrence	Format	Access type
ZeroOrOne	Chr	Add, Replace

The Passwd leaf defines the password for outbound proxy/P-CSCF realm.

2.2.20 `./SIP/<X>/OutboundProxy/Realm`

Occurrence	Format	Access type
ZeroOrOne	Chr	Add, Get, Replace

The Realm leaf defines the realm for outbound proxy/P-CSCF.

Note that the Realm leaf must hold exactly the same text string that the proxy server returns in the realm parameter of the Proxy-Authenticate header of 407 response to REGISTER.

2.2.21 `./SIP/<X>/RegistrarServer`

Occurrence	Format	Access type
One	Node	Add, Get

Node for registrar server settings.

2.2.22 `./SIP/<X>/RegistrarServer/Host`

Occurrence	Format	Access type
ZeroOrOne	Chr	Add, Get, Replace

The Host leaf defines the address of the registrar server/S-CSCF. IPV4/6 address, domain, or FQDN.

2.2.23 `./SIP/<X>/RegistrarServer/Port`

Occurrence	Format	Access type
ZeroOrOne	Int	Add, Get, Replace

The Port leaf defines the port number of the registrar server.

Note: This parameter is effective only when the ProfileType parameter is set to IETF.

2.2.24 ./SIP/<X>/RegistrarServer/Transport

Occurrence	Format	Access type
ZeroOrOne	Chr	Add, Get, Replace

The Transport leaf defines the transport protocol to be used between the terminal and the registrar server.

Note: This parameter is effective only when the ProfileType parameter is set to IETF.

Values	Description
TCP	TCP is used as transport protocol.
UDP	UDP is used as transport protocol.
Auto	Transport protocol is automatic.

2.2.25 ./SIP/<X>/RegistrarServer/Username

Occurrence	Format	Access type
ZeroOrOne	Chr	Add, Get, Replace

The Username leaf defines the user name for the registrar server realm.

Note: This parameter is effective only when the ProfileType parameter is set to IETF.

2.2.26 ./SIP/<X>/RegistrarServer/PrivateIdentity

Occurrence	Format	Access type
ZeroOrOne	Chr	Add, Get, Replace

The PrivateUserIdentity leaf defines the private user identity for the S-CSCF realm.

Note: This parameter is effective only when the ProfileType parameter is set to ims.

2.2.27 ./SIP/<X>/RegistrarServer/Passwd

Occurrence	Format	Access type
ZeroOrOne	Chr	Add, Replace

The Passwd leaf defines the password for the registrar server/S-CSCF realm.

2.2.28 .SIP/<X>/RegistrarServer/Realm

Occurrence	Format	Access type
ZeroOrOne	Chr	Add, Get, Replace

The Realm leaf defines the realm for the registrar server/S-CSCF.

Note that the Realm leaf must be exactly the same text string that the registrar server returns in the realm parameter of the WWW-Authenticate header of 401 response to REGISTER.

3 Terms and abbreviations

Term or abbreviation	Meaning
AP	Access Point
DM	Device Management
FQDN	Fully Qualified Domain Name
IETF	Internet Engineering Task Force
IMS	IP Multimedia Subsystem
IPv4/6	Internet Protocol version 4/6
OMA	Open Mobile Alliance
P-CSCF	Proxy - Call State Control Function (analogous to outbound proxy)
S-CSCF	Serving - Call State Control Function (analogous to registrar proxy)
SIP	Session Initiation Protocol
SyncML	Synchronization Mark-up Language
TCP	Transmission Control Protocol
UDP	User Datagram Protocol
URI	Uniform Resource Identifier
VoIP	Voice Over IP

4 References

- [1] OMA Device Management Standardized Objects, Open Mobile Alliance Ltd. <http://www.openmobilealliance.com/>
- [2] OMA Device Management Tree and Description, Open Mobile Alliance Ltd. <http://www.openmobilealliance.com/>
- [3] Internet Protocol [RFC791], The Internet Engineering Task Force (IETF) <http://www.ietf.org/>
- [4] Uniform Resource Identifiers (URI): Generic Syntax [RFC2396], The Internet Engineering Task Force (IETF) <http://www.ietf.org/>
- [5] Session Initiation Protocol (SIP): Locating SIP Servers [RFC3263], The Internet Engineering Task Force (IETF) <http://www.ietf.org/>

5 Evaluate this resource

Please spare a moment to help us improve documentation quality and recognize the resources you find most valuable, by [rating this resource](#).